

HYDRAULIC MOTORS & MOTOR-BRAKE

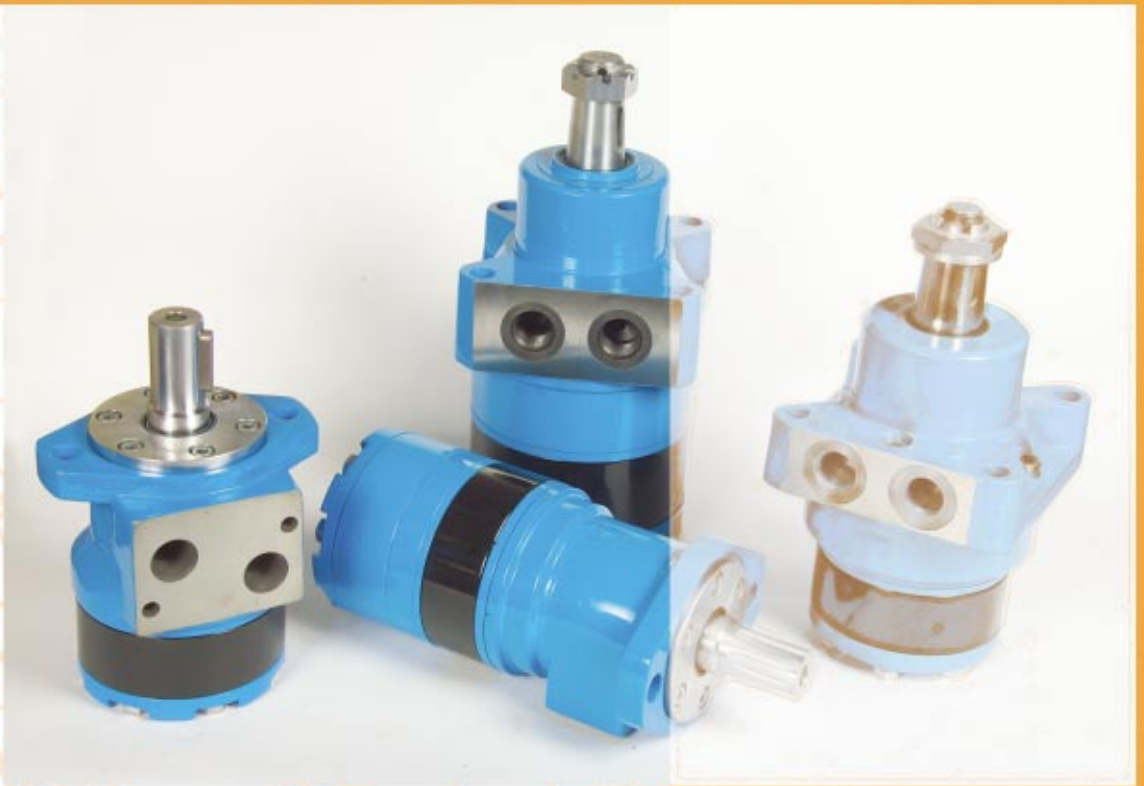

TYPE PL; RL; RW
HW; PK; RK
TYPE B/MR

HYDRAULIC MOTORS

CONTENTS

	Page
● Hydraulic Motors Series PL	4
● Hydraulic Motors Series RL	14
● Hydraulic Motors Series RW	24
● Hydraulic Motors Series HW	33
● Hydraulic Motors Series PK	40
● Hydraulic Motors Series RK	45
● Hydraulic Motor-brakes Series B/MR	49
● Motor Special Features	54
● Motor Application	55

SPOOL VALVE HYDRAULIC MOTORS

The operating principle of the motors is based on an internal gear design, consisting of a stator and rotor through which the output torque and speed are transmitted. The distributor valve is driven synchronously by the rotor through a cardan shaft ensuring that each one of the chambers of the motor are filled and emptied precisely.

PL , RL, RW and HW motors have a Spool Valve.

SPOOL VALVE - The distributor valve has been integrated with the output shaft. The valve has hydrodynamic bearings, and has infinite life when load ratings are not exceeded.

GEAR SET - There are two forms of stator, hence and of gear set:

EPML have plain teeth. These types motors are suitable for long operating periods at moderate pressures- or short operating periods at high pressures.

EPRML have teeth fitted with rollers. The rollers reduce local stress and the tangential reaction forces on the rotor reducing friction to a minimum. This gives long operating life and better efficiency even at continuous high pressures. Roller Gear Sets are recommended for operation with thin oil and for applications having continually reversing loads.

Standard Motor The standard motor mounting flange is located as close to the output shaft as possible. This type of mounting supports the motor close to the shaft load. This mounting flange is also compatible with many standard gear boxes.

Low Leakage **LL** Series hydraulic motors have been designed to operate at the whole standard range of working conditions (pressure drop and frequency of rotation) , but with considerable decreased volumetric losses in the drainage ports. Their main purpose is to operate as series-connected motors in hydraulic systems. For this version is permissible decreasing of the maximal torque with up to 5% (at middle speed) and up to 10 % (at high speed) in comparison to the standard versions of motors.

Low Speed Valve **LSV** Series hydraulic motors have been designed to operate with normal pressure drop and to ensure smooth run at low speed (up to 200 min^{-1}), as the best security for operation is guaranteed at frequency of rotation $20 \div 50 \text{ min}^{-1}$. They have an increased starting pressure drop and are not recommended for using at pressure less than 40 bar.

Free Running **FR** Series hydraulic motors have been designed to operate with high frequencies of rotation /over than 300 min^{-1} / and low pressure drop. These motors are produced with increased clearance at all friction parts. Additional advantages of "FR" version are prolonging of the life of the hydraulic motors at high frequencies of rotation, as well as the possibility to use them in systems with big variation of the loading. Volumetric efficiency can be affected.

HYDRAULIC MOTORS PL



APPLICATION

- » Conveyors
- » Feeding mechanism of robots and manipulators
- » Metal working machines
- » Textile machines
- » Machines for agriculture
- » Food industries
- » Mining machinery etc.

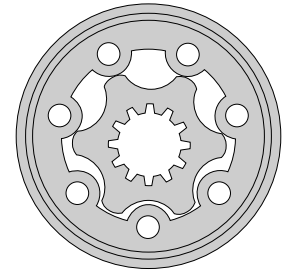

CONTENTS

Specification data 5
 Function diagrams 6 ÷ 10
 Permissible shaft loads 10
 Dimensions and mounting ... 11
 Shaft extensions 12
 Order code 13

OPTIONS

- » Model- Spool valve, gerotor
- » Antifriction conical bearing
- » Flange mount
- » Shafts- straight, splined and tapered
- » Metric and BSPP ports
- » Other special features

GENERAL

Displacement, [cm ³ /rev.]	49,5 ÷ 396
Max. Speed, [RPM]	150 ÷ 1210
Max. Torque, [daNm]	9,4 ÷ 50
Max. Output, [kW]	9,9 ÷ 11,7
Max. Pressure Drop, [bar]	95 ÷ 140
Max. Oil Flow, [l/min]	60
Min. Speed, [RPM]	10
Permissible Shaft Loads, [daN]	P _a = 500
Pressure fluid	Mineral based- HLP(DIN 51524) or HM(ISO 6743/4)
Temperature range, [°C]	-30 ÷ 90
Optimal Viscosity range, [mm ² /s]	20 ÷ 75
Filtration	ISO code 20/16 (Min. recommended fluid filtration of 25 micron)

Oil flow in drain line

Pressure drop (bar)	Viscosity (mm ² /s)	Oil flow in drain line (l/min)
100	20	2,5
	35	1,8
140	20	3,5
	35	2,8

Pressure Losses

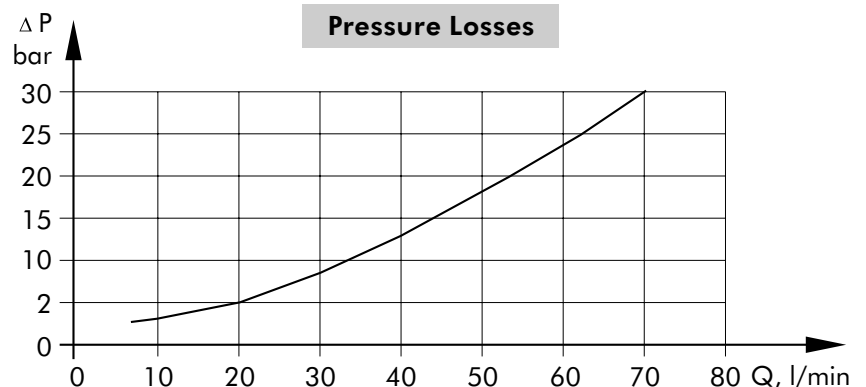

SPECIFICATION DATA

Type		PL 50	PL 80	PL 100	PL 125	PL 160	PL 200	PL 250	PL 315	PL 400
Displacement, [cm.³/rev.]		49,5	79,2	99	123,8	158,4	198	247,5	316,8	396
Max. Speed, [RPM]	Cont.	1210	755	605	485	378	303	242	190	150
	Int.*	1515	945	755	605	472	378	303	236	189
Max. Torque [daNm]	Cont.	9,4	15,1	19,3	23,7	31,3	36,6	47,0	48,6	50,0
	Int.*	11,9	19,5	23,7	29,8	37,8	45,6	58,3	56,0	59,0
	Peak**	14,0	22,0	27,0	36,5	42	53,0	67,0	85,0	85,4
Max. Output [kW]	Cont.	9,9	9,9	9,9	9,9	11,7	10,3	9,8	7,6	6,6
	Int.*	12,5	12,5	12,5	12,5	12,5	15,5	17,5	8,2	9,2
Max. Pressure Drop [bar]	Cont.	140	140	140	140	140	140	140	120	95
	Int.*	175	175	175	175	175	175	175	140	115
	Peak**	225	225	225	225	225	225	225	225	180
Max. Oil Flow [l/min]	Cont.	60	60	60	60	60	60	60	60	60
	Int.*	75	75	75	75	75	75	75	75	75
Max. Inlet Pressure [bar]	Cont.	175	175	175	175	175	175	175	175	175
	Int.*	200	200	200	200	200	200	200	200	200
	Peak**	225	225	225	225	225	225	225	225	225
Max. Return Pressure without Drain Line or Max. Pressure in Drain Line, [bar]	Cont. 0-100 RPM	100	100	100	100	100	100	100	100	100
	Cont. 100-300 RPM	50	50	50	50	50	50	50	50	50
	Cont. 300-600 RPM	25	25	25	25	25	25	25	25	25
	Cont. >600 RPM	15	15	15	15	15	15	15	15	15
	Int.* 0-max. RPM	100	100	100	100	100	100	100	100	100
Max. Return Pressure with Drain Line [bar]	Cont.	175	175	175	175	175	175	175	175	175
	Int.*	200	200	200	200	200	200	200	200	200
	Peak**	225	225	225	225	225	225	225	225	225
Max. Starting Pressure with Unloaded Shaft, [bar]		10	10	10	9	8	7	6	5	5
Min. Starting Torque [daNm]		7,7	14,0	16,8	21,0	28,0	32,2	41,4	43,0	44,0
Min. Speed***, [RPM]		10	10	10	10	10	10	10	10	10
Weight, [kg]		8,4	8,5	8,8	8,9	9,1	9,5	10,0	10,7	11,4

* Intermittent operation: the permissible values may occur for max. 10% of every minute.

** Peak load: the permissible values may occur for max. 1% of every minute.

*** For speeds of 10 RPM or lower, consult factory or your regional manager.

1. Intermittent speed and intermittent pressure drop must not occur simultaneously.
2. Recommended filtration is per ISO cleanliness code 20/16. A nominal filtration of 25 micron or better.
3. Recommended using a premium quality, anti-wear type mineral based hydraulic oil HLP(DIN51524) or HM (ISO 6743/4).
If using synthetic fluids consult the factory for alternative seal materials.
4. Recommended minimum oil viscosity 13 mm²/s at operating temperatures.
5. Recommended maximum system operating temperature is 82°C.
6. To assure optimum motor life fill with fluid prior to loading and run at moderate load and speed for 10-15 minutes.

FUNCTION DIAGRAMS

PL 50

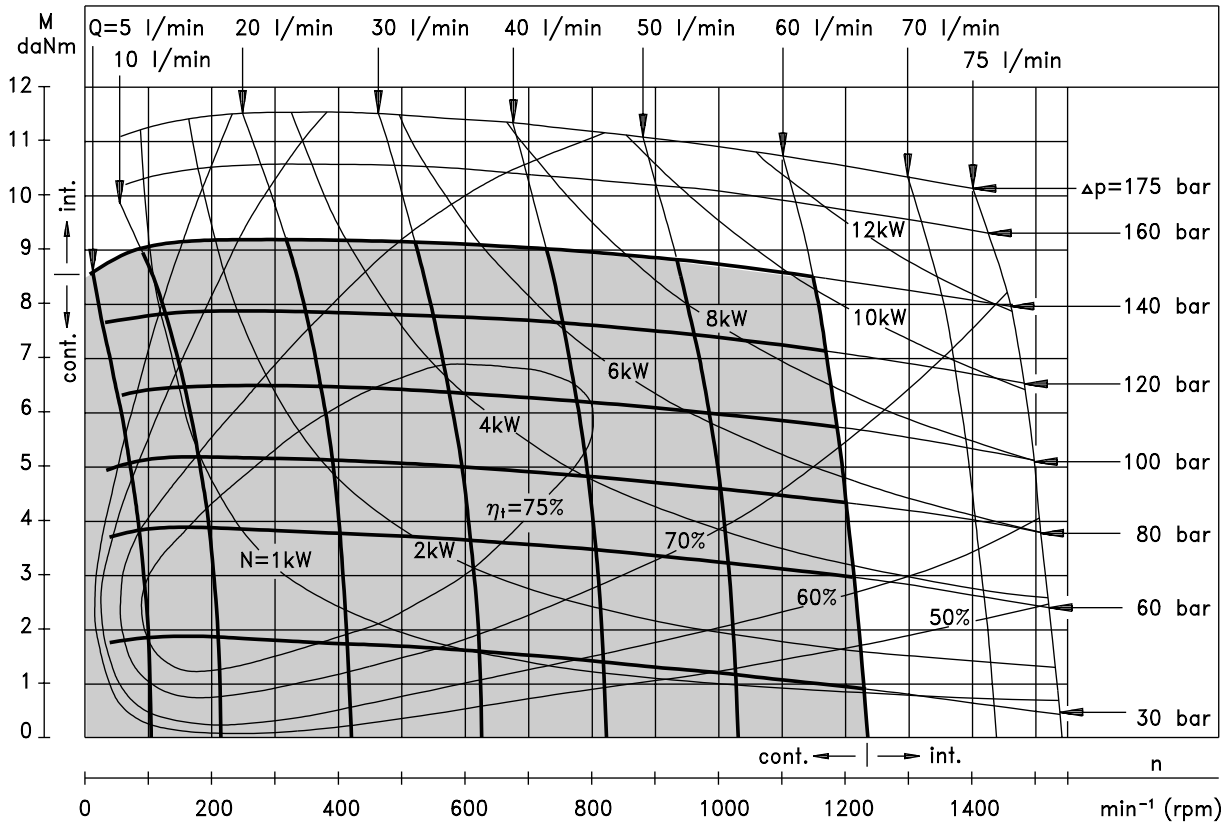

PL 80

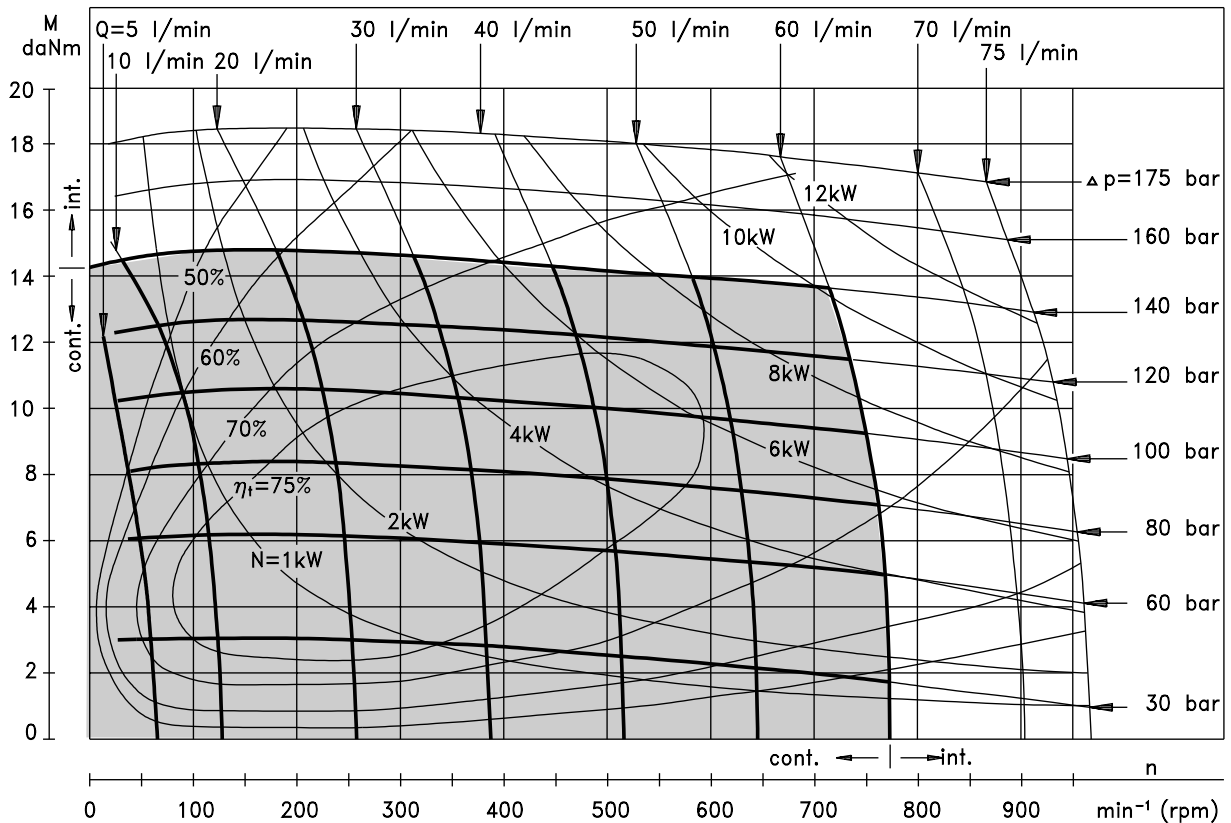

The function diagrams data was collected at back pressure 5÷10 bar and oil with viscosity of 32 mm²/s at 50° C.

FUNCTION DIAGRAMS

PL 100

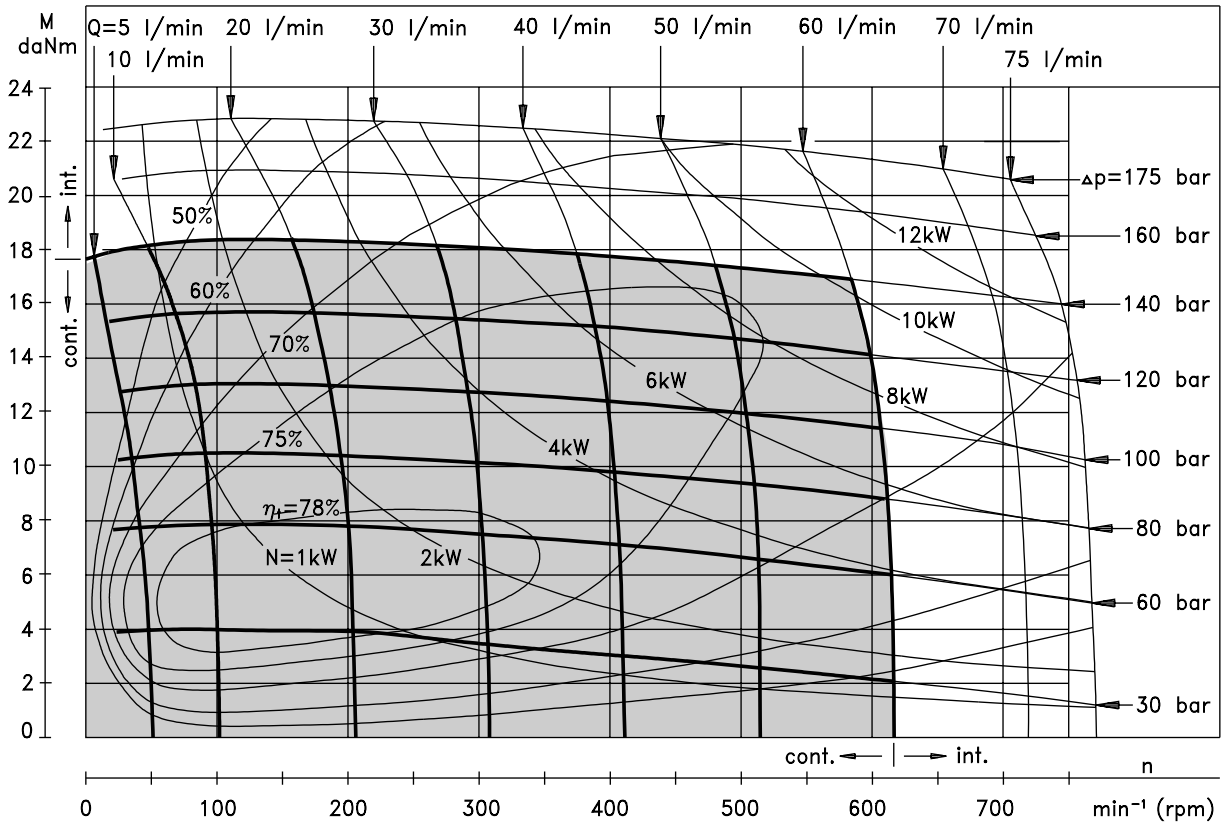

PL 125

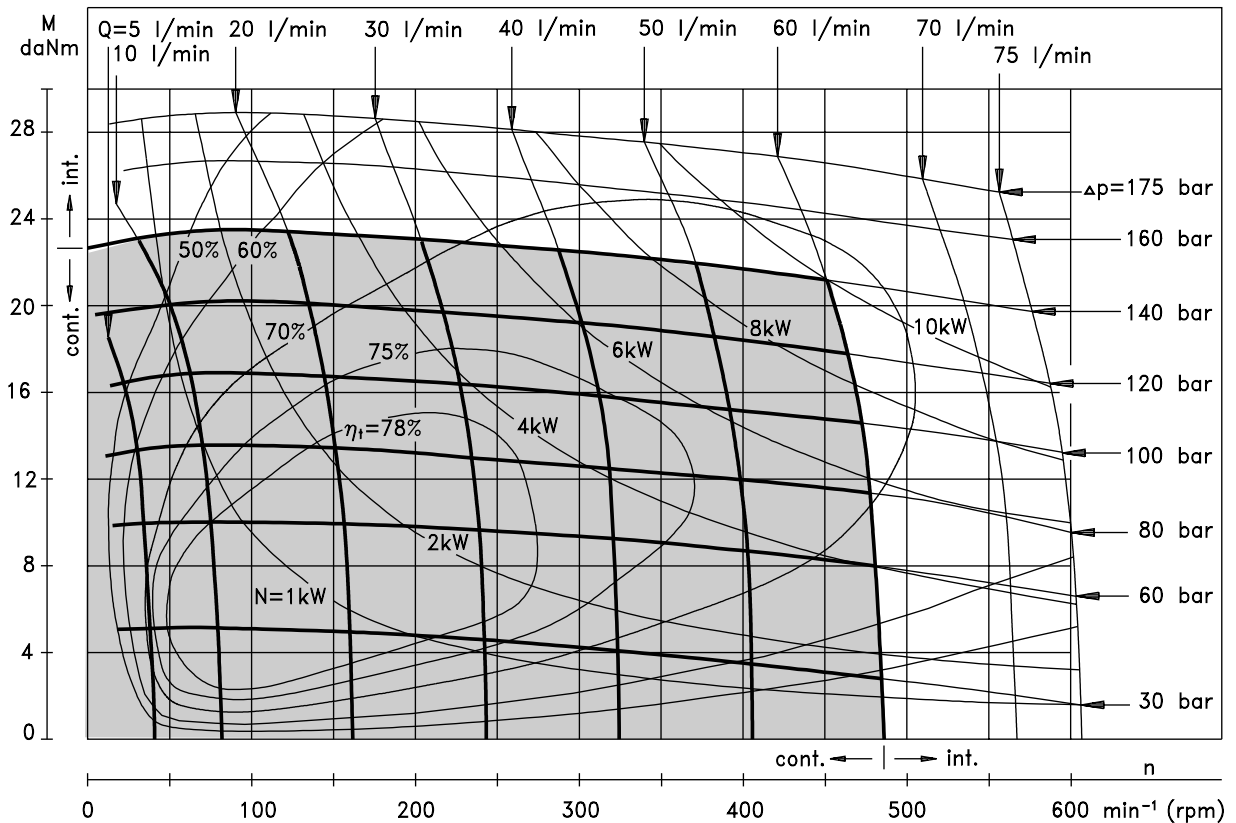

The function diagrams data was collected at back pressure 5 ÷ 10 bar and oil with viscosity of 32 mm²/s at 50° C.

FUNCTION DIAGRAMS

PL 160

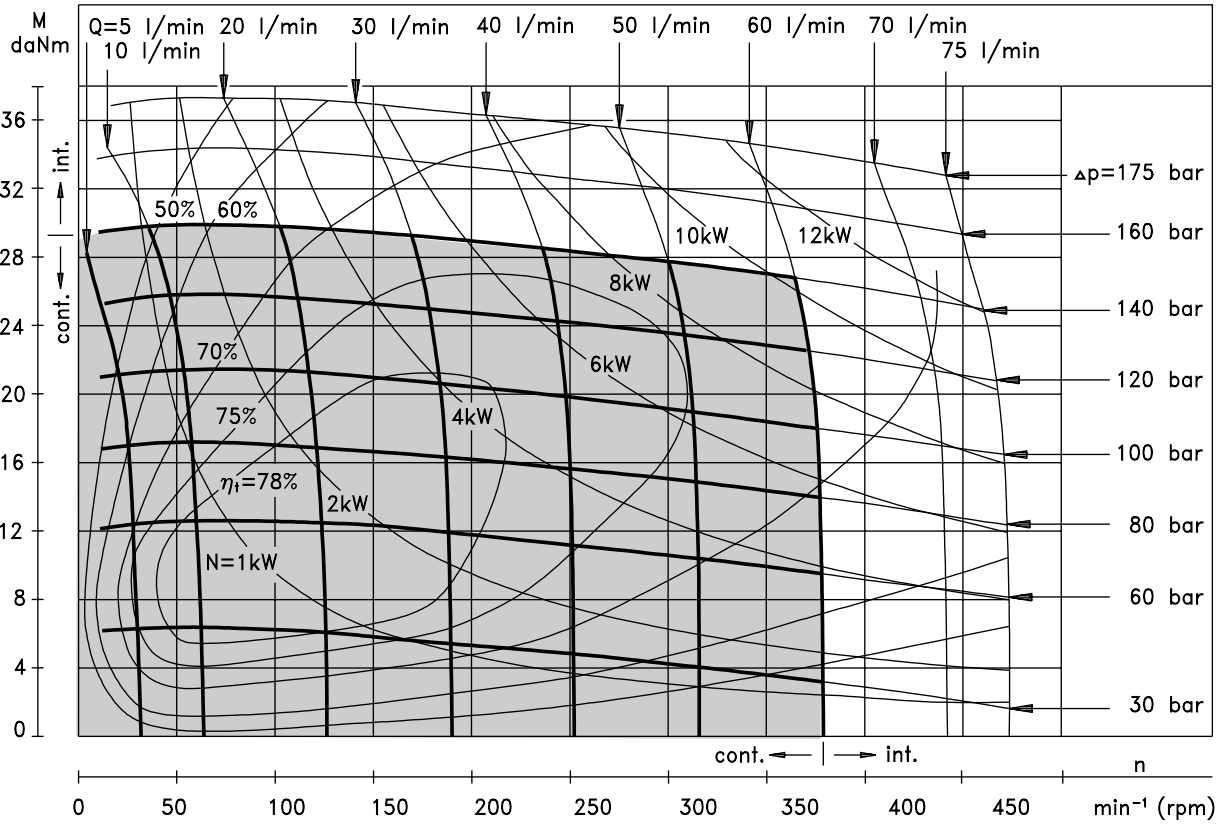

PL 200

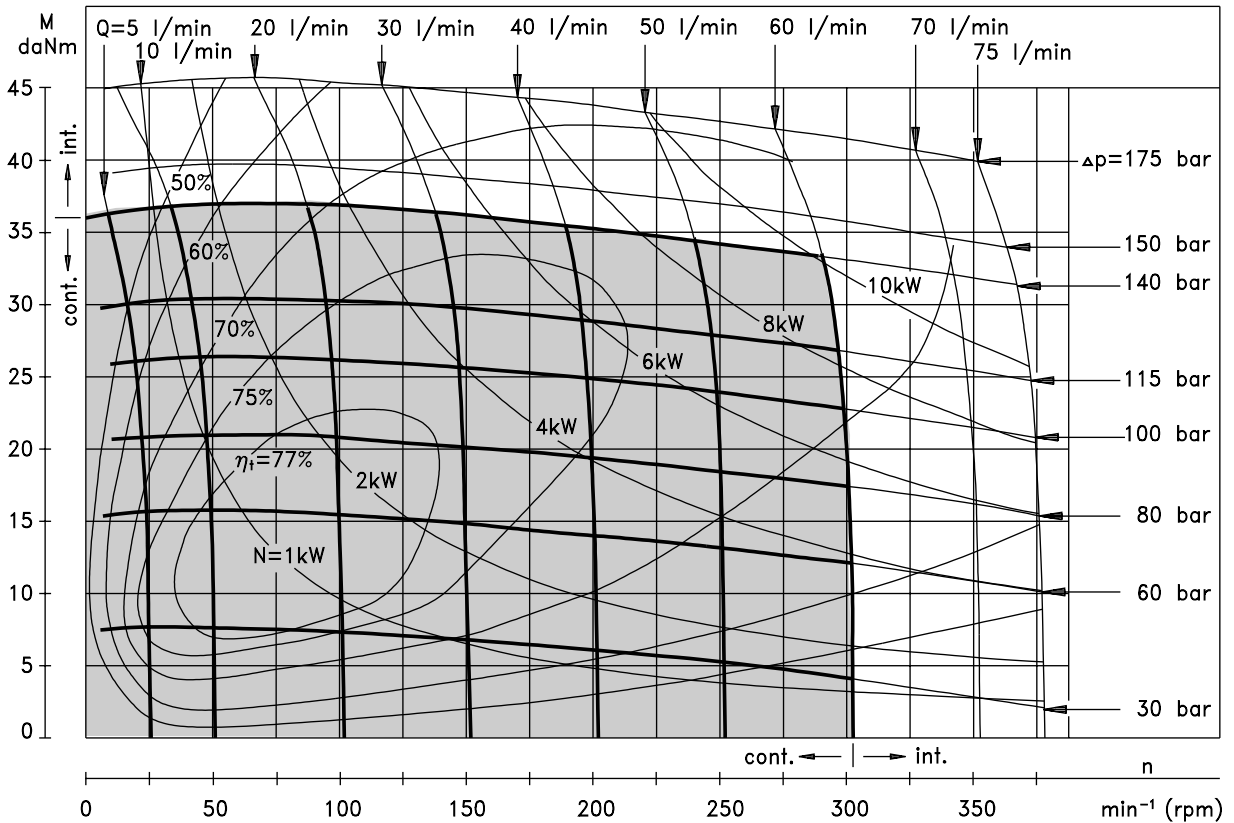

The function diagrams data was collected at back pressure 5 ÷ 10 bar and oil with viscosity of 32 mm²/s at 50° C.

FUNCTION DIAGRAMS

PL 250

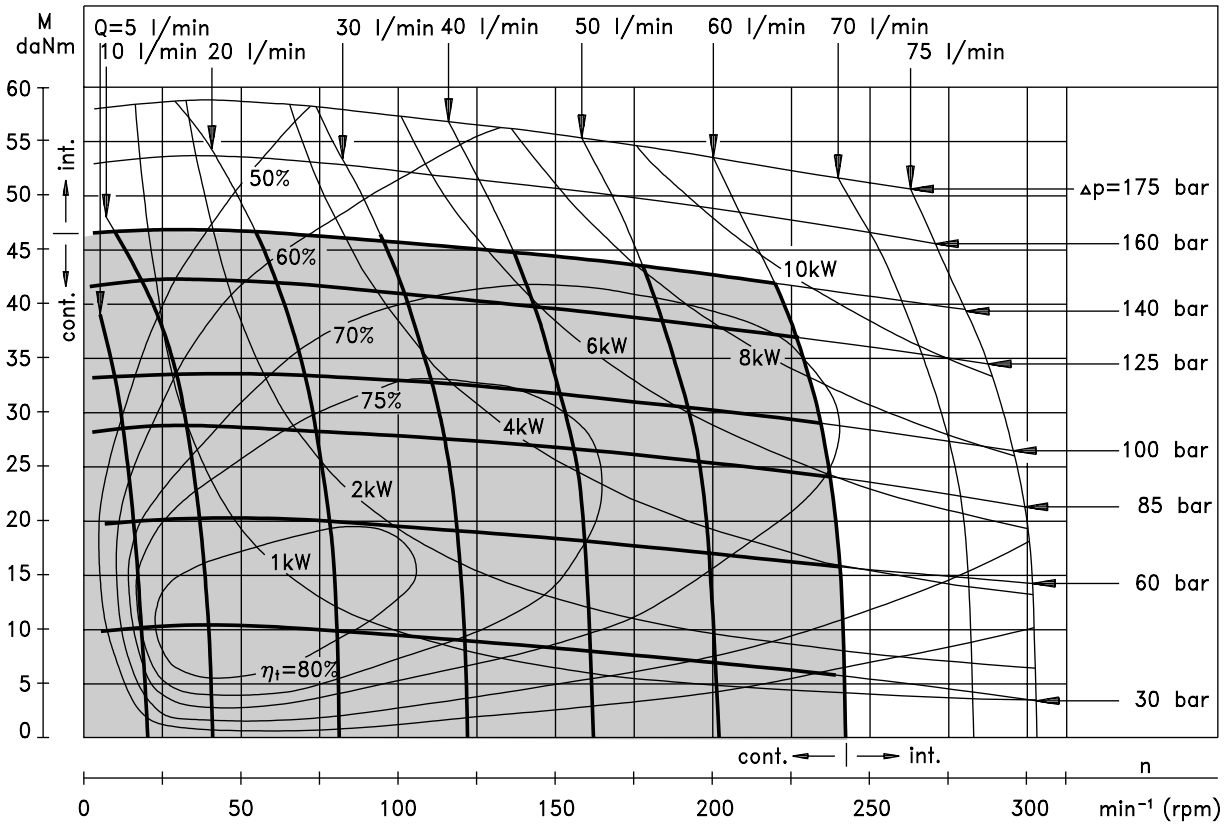

PL 315

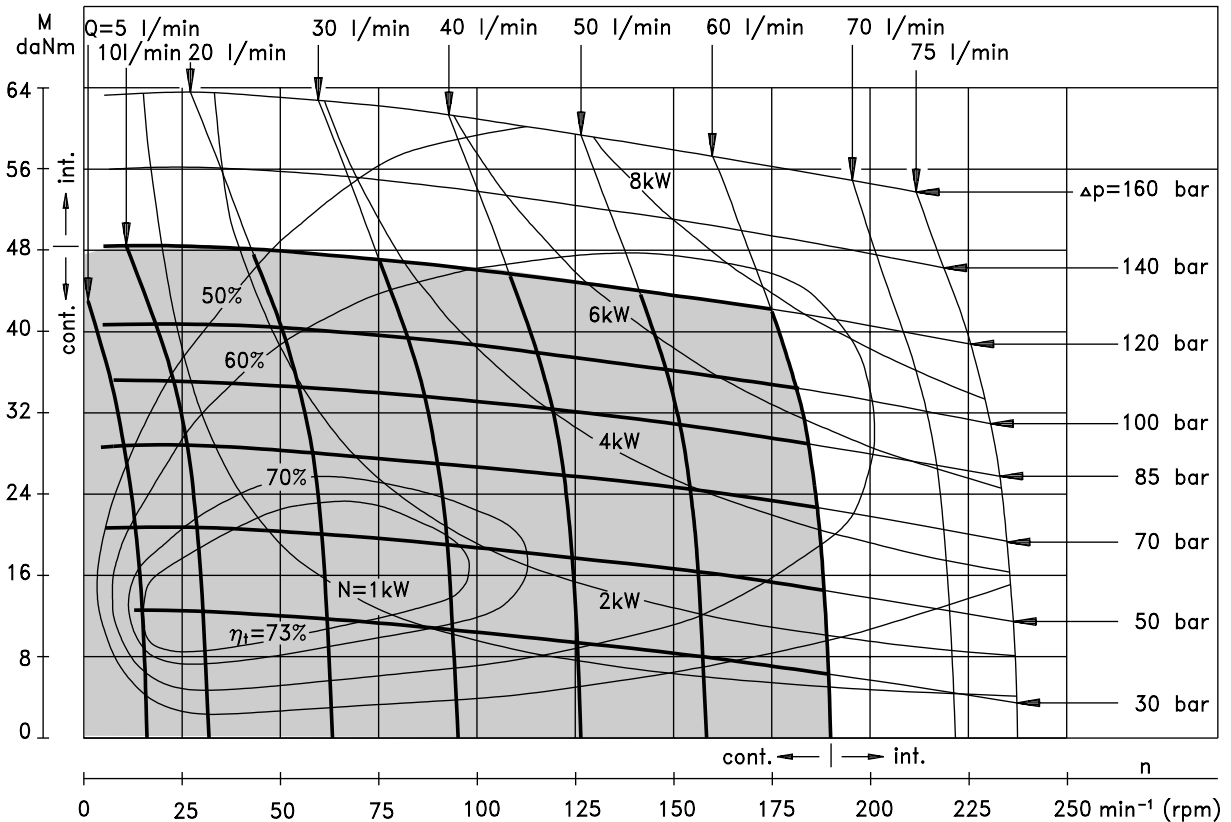

The function diagrams data was collected at back pressure 5 ÷ 10 bar and oil with viscosity of 32 mm^2/s at 50° C.

FUNCTION DIAGRAM

PL 400

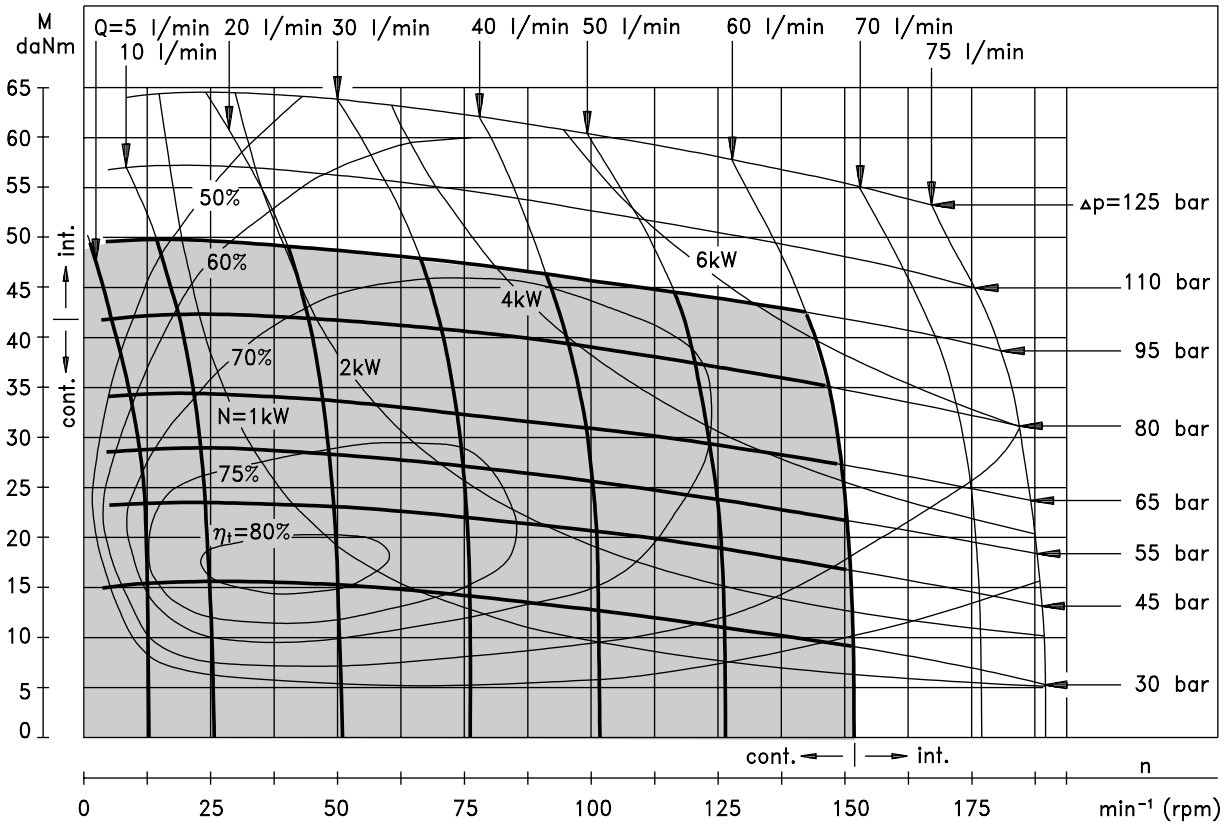

The function diagram data was collected at back pressure 5 ÷ 10 bar and oil with viscosity of 32 mm²/s at 50° C.

Permissible Shaft Loads PL

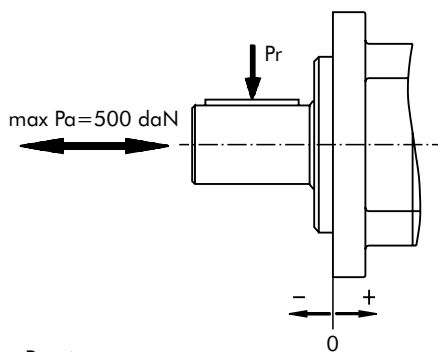

- A- Static load
- B- $P_a = 200 \text{ daN}$
- C- $P_a = 500 \text{ daN}$

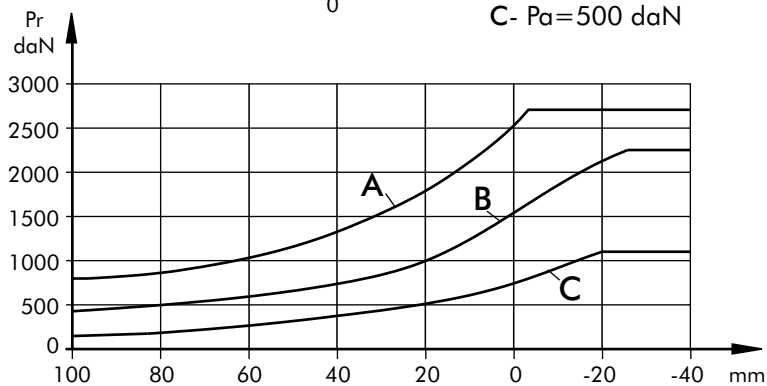

DIMENSIONS AND MOUNTING DATA

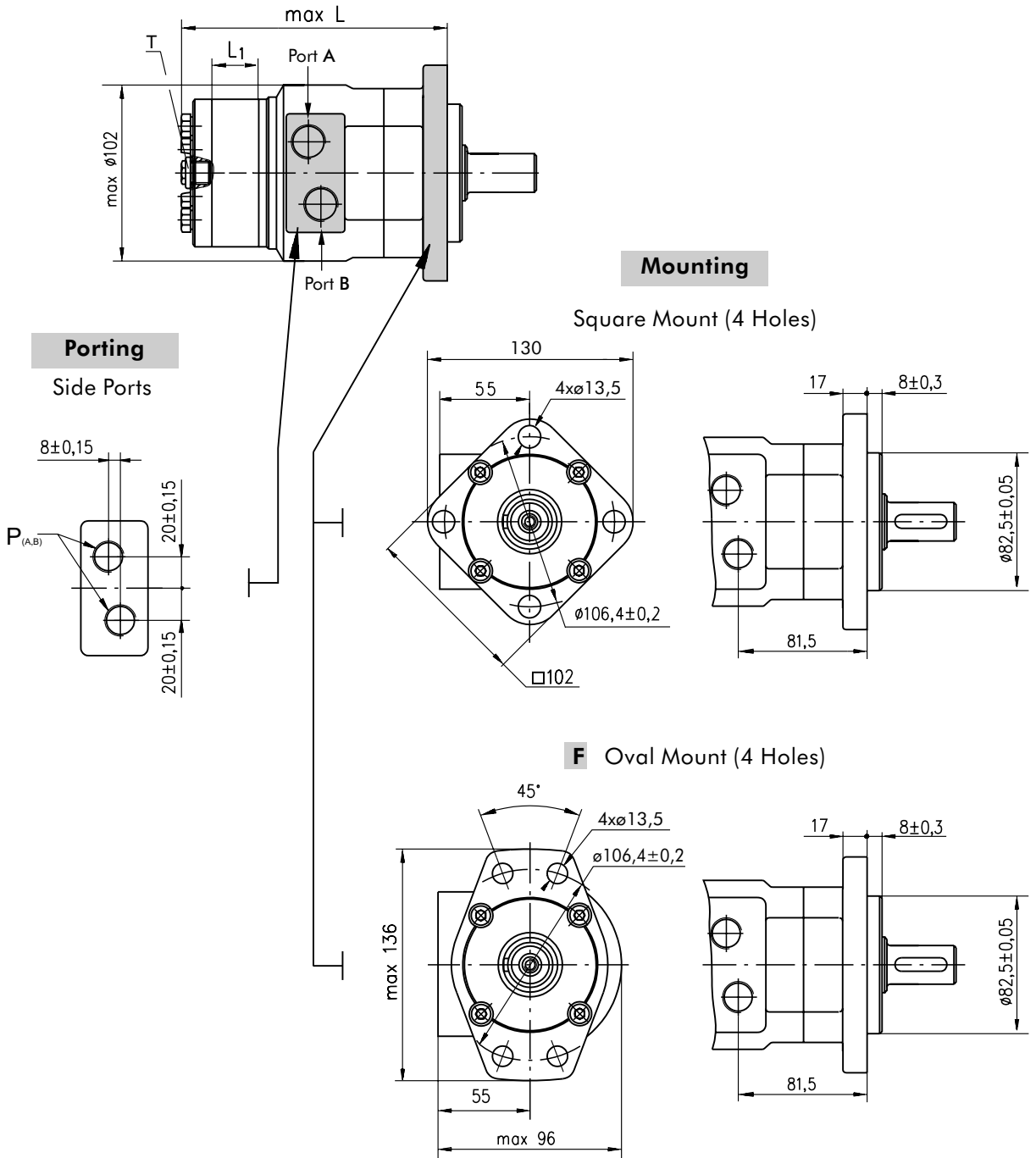

Type	L, mm	L1, mm
PL 50	148	6,67
PL 80	152	10,67
PL 100	155	13,33
PL 125	158	16,67
PL 160	163	21,33
PL 200	168	26,67
PL 250	175	33,33
PL 315	184	42,67
PL 400	195	53,33

P_(A,B): 2xG1/2 or 2xM22x1,5 - 15 mm depth
T : G1/4 or M14x1,5 - 12 mm depth (plugged)

Standard Rotation
 Viewed from Shaft End
 Port A Pressurized - CW
 Port B Pressurized - CCW

Reverse Rotation
 Viewed from Shaft End
 Port A Pressurized - CCW
 Port B Pressurized - CW

SHAFT EXTENSIONS

C - $\varnothing 25$ straight, Parallel key A8x7x30 DIN 6885
Max. Torque 34 daNm

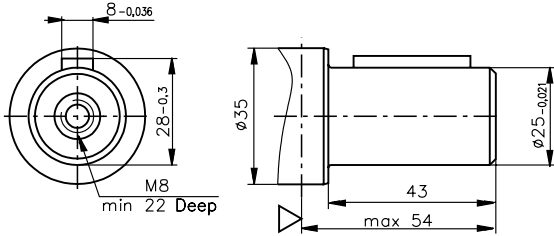

SA - splined B25x22 DIN 5482
Max. Torque 40 daNm

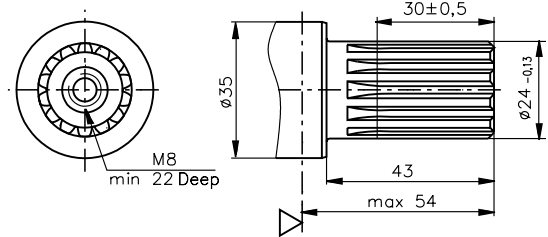

CO - $\varnothing 1"$ straight, Parallel key $\frac{1}{4} \times \frac{1}{4} \times 1 \frac{1}{4}$ " BS46
Max. Torque 34 daNm

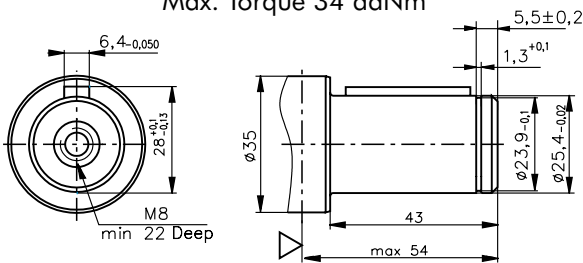

CB - $\varnothing 32$ straight, Parallel key A10x8x40 DIN 6885
Max. Torque 77 daNm

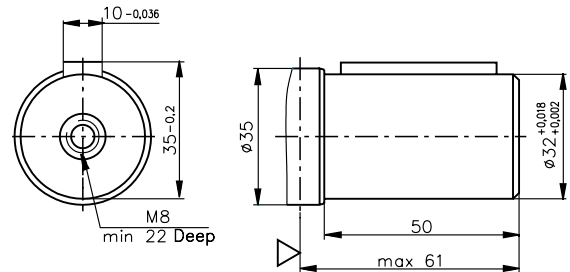

SH - splined, BS 2059 (SAE 6B)
Max. Torque 40 daNm

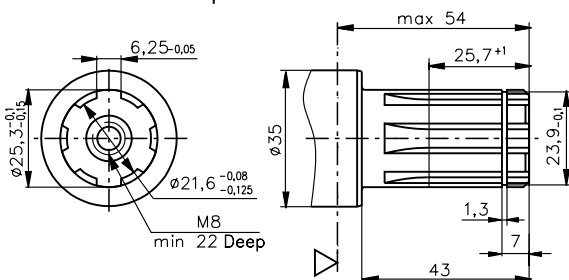

HB - $\varnothing 1 \frac{1}{4}$ " splined 14T, DP12/24 ANSI B92.1-1976
Max. Torque 95 daNm

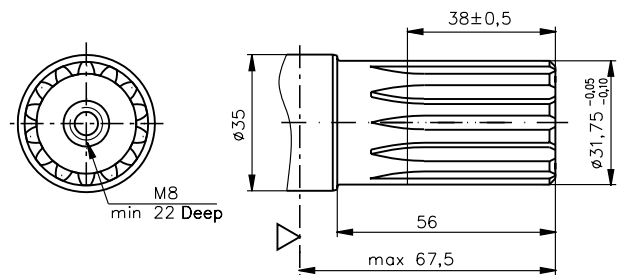

KB - tapered 1:10, Woodruff key 6x9 DIN6888
Max. Torque 95 daNm

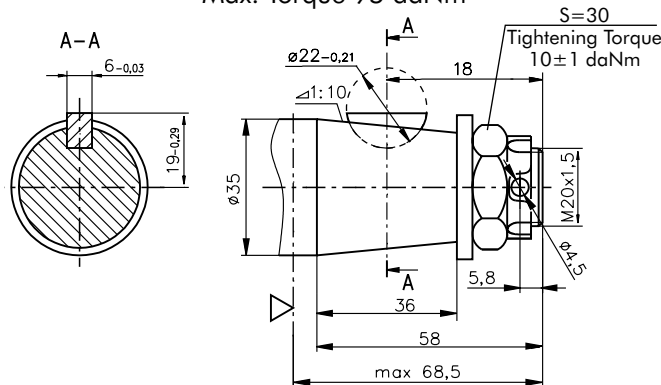

▽ - Motor Mounting Surface

ORDER CODE

	1	2	3	4	5	6
PL						

Pos. 1 - Mounting Flange

omit - Square mount, four holes

F - Oval mount, four holes

Pos. 2 - Displacement code

50 - 49,5 [cm³/rev]

80 - 79,2 [cm³/rev]

100 - 99,0 [cm³/rev]

125 - 123,8 [cm³/rev]

160 - 158,4 [cm³/rev]

200 - 198,0 [cm³/rev]

250 - 247,5 [cm³/rev]

315 - 316,8 [cm³/rev]

400 - 396,0 [cm³/rev]

Pos. 3 - Shaft extensions*

C - ø25 straight, Parallel key A8x7x30 DIN6885

CO - ø1" straight, Parallel key ¼"x¼"x1 ¼" BS46

SH - ø25,3 splined BS 2059 (SAE 6B)

SA - ø24 splined B 25x22 DIN 5482

CB - ø32 straight, Parallel key A10x8x40 DIN6885

HB - ø1 ¼" splined 14T ANSI B92.1 - 1976

KB - ø35 tapered 1:10, Woodruff key 6x9 DIN6888

Pos. 4 - Ports

omit - BSPP (ISO 228)

M - Metric (ISO 262)

Pos. 5 - Special Features [\(see page 53\)](#)

Pos. 6 - Design Series

omit - Factory specified

NOTES:

* The permissible output torque for shafts must not be exceeded!

The hydraulic motors are mangano-phosphatized as standard.

HYDRAULIC MOTORS RL



APPLICATION

- » Conveyors
- » Feeding mechanism of robots and manipulators
- » Metal working machines
- » Textile machines
- » Machines for agriculture
- » Food industries
- » Mining machinery etc.

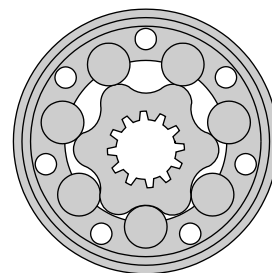

CONTENTS

Specification data 15
 Function diagrams 16÷20
 Permissible shaft loads 20
 Dimensions and mounting ... 21
 Shaft extensions 22
 Order code 23

OPTIONS

- » Model- Spool valve, roll-gerotor
- » Antifriction conical bearings
- » Flange mount
- » Shafts- straight, splined and tapered
- » Metric and BSPP ports
- » Other special features

GENERAL

Displacement,	[cm ³ /rev.]	51,5 ÷ 397
Max. Speed,	[RPM]	150 ÷ 775
Max. Torque,	[daNm]	10,1 ÷ 61
Max. Output,	[kW]	7 ÷ 13
Max. Pressure Drop,	[bar]	115 ÷ 175
Max. Oil Flow,	[l/min]	60
Min. Speed,	[RPM]	10
Permissible Shaft Loads,	[daN]	P _o = 500
Pressure fluid		Mineral based- HLP(DIN 51524) or HM(ISO 6743/4)
Temperature range,	[°C]	-30 ÷ 90
Optimal Viscosity range,	[mm ² /s]	20 ÷ 75
Filtration		ISO code 20/16 (Min. recommended fluid filtration of 25 micron)

Oil flow in drain line

Pressure drop (bar)	Viscosity (mm ² /s)	Oil flow in drain line (l/min)
100	20	2,5
	35	1,8
140	20	3,5
	35	2,8

Pressure Losses

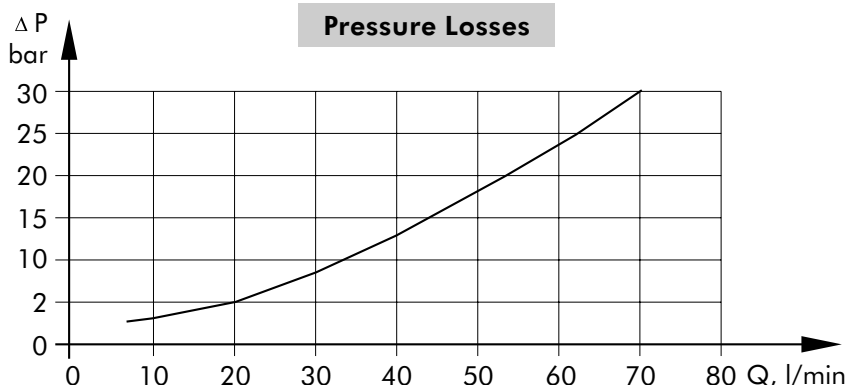

SPECIFICATION DATA

Type	RL 50	RL 80	RL 100	RL 125	RL 160	RL 200	RL 250	RL 315	RL 400	
Displacement, [cm.³/rev.]	51,5	80,3	99,8	125,7	159,6	199,8	250,1	315,7	397	
Max. Speed, [RPM]	Cont.	775	750	600	475	375	300	240	190	150
	Int.*	970	940	750	600	470	375	300	240	190
Max. Torque [daNm]	Cont.	10,1	20,0	24,0	30,0	39,0	45,0	54,0	55,0	61,0
	Int.*	13,0	22,0	28,0	34,0	43,0	50,0	61,0	63,0	69,0
	Peak**	17,0	27,0	32,0	37,0	46,0	56,0	71,0	83,0	87,0
Max. Output [kW]	Cont.	7	12,5	13,0	12,5	11,5	11,0	10,0	9,0	7,8
	Int.*	8,5	15,0	15,0	16,0	14,0	13,0	12,0	11,0	10,6
Max. Pressure Drop [bar]	Cont.	140	175	175	175	175	175	175	135	115
	Int.*	175	200	200	200	200	200	200	160	140
	Peak**	225	225	225	225	225	225	225	210	175
Max. Oil Flow [l/min]	Cont.	40	60	60	60	60	60	60	60	60
	Int.*	50	75	75	75	75	75	75	75	75
Max. Inlet Pressure [bar]	Cont.	175	175	175	175	175	175	175	175	175
	Int.*	200	200	200	200	200	200	200	200	200
	Peak**	225	225	225	225	225	225	225	225	225
Max. Return Pressure without Drain Line or Max. Pressure in Drain Line, [bar]	Cont. 0-100 RPM	100	100	100	100	100	100	100	100	100
	Cont. 100-300 RPM	50	50	50	50	50	50	50	50	50
	Cont. 300-600 RPM	25	25	25	25	25	25	25	25	25
	Cont. >600 RPM	15	15	15	15	15	15	15	15	15
Int.* 0-max. RPM	100	100	100	100	100	100	100	100	100	
Max. Return Pressure with Drain Line [bar]	Cont.	140	175	175	175	175	175	175	175	175
	Int.*	175	200	200	200	200	200	200	200	200
	Peak**	225	225	225	225	225	225	225	225	225
Max. Starting Pressure with Unloaded Shaft, [bar]	10	10	10	9	7	5	4	3	3	
Min. Starting Torque [daNm]	8	15	20	25	32	37	45	45	49	
Min. Speed***, [RPM]	10	10	10	10	10	10	10	10	10	
Weight, [kg]	8,5	8,6	8,9	9,0	9,2	9,6	10,1	10,8	11,5	

* Intermittent operation: the permissible values may occur for max. 10% of every minute.

** Peak load: the permissible values may occur for max. 1% of every minute.

*** For speeds of 10 RPM or lower, consult factory or your regional manager.

1. Intermittent speed and intermittent pressure drop must not occur simultaneously.
2. Recommended filtration is per ISO cleanliness code 20/16. A nominal filtration of 25 micron or better.
3. Recommended using a premium quality, anti-wear type mineral based hydraulic oil HLP(DIN51524) or HM (ISO 6743/4).
If using synthetic fluids consult the factory for alternative seal materials.
4. Recommended minimum oil viscosity 13 mm²/s at operating temperatures.
5. Recommended maximum system operating temperature is 82°C.
6. To assure optimum motor life fill with fluid prior to loading and run at moderate load and speed for 10-15 minutes.

FUNCTION DIAGRAMS

RL 50

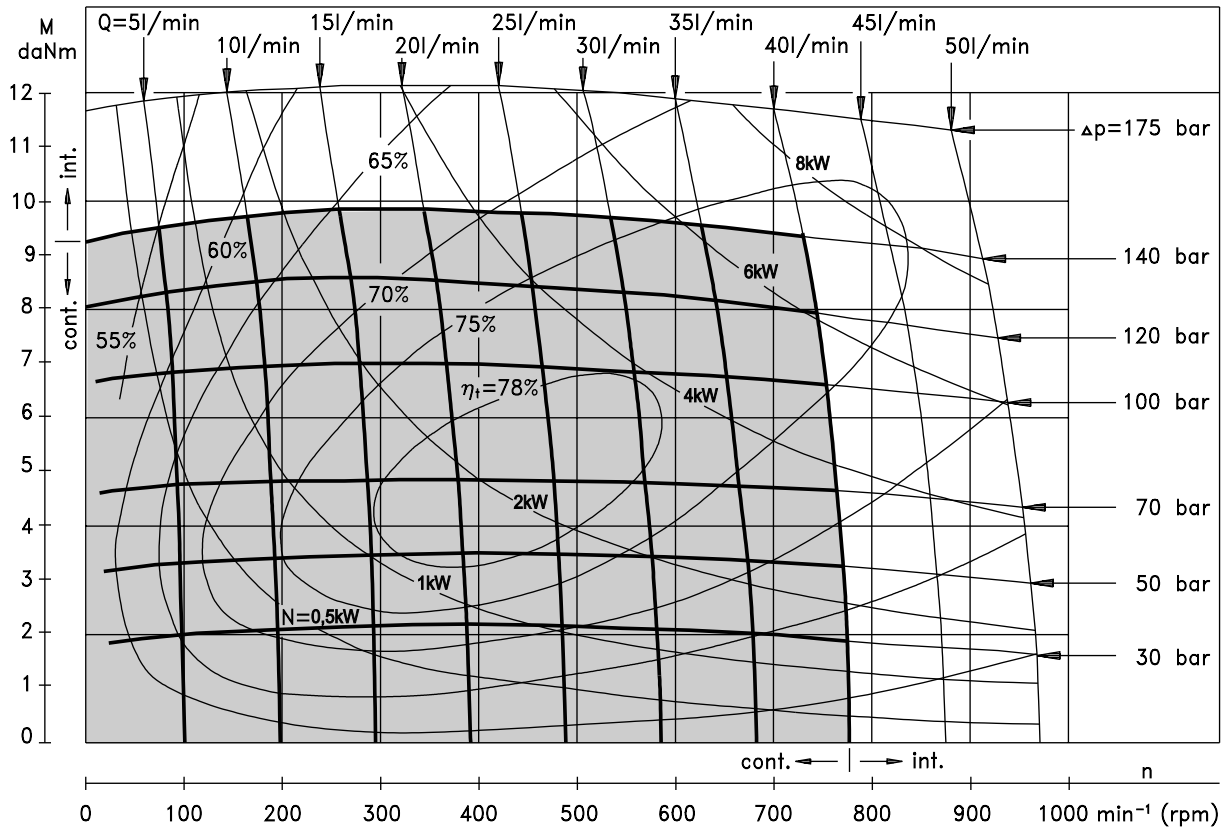

RL 80

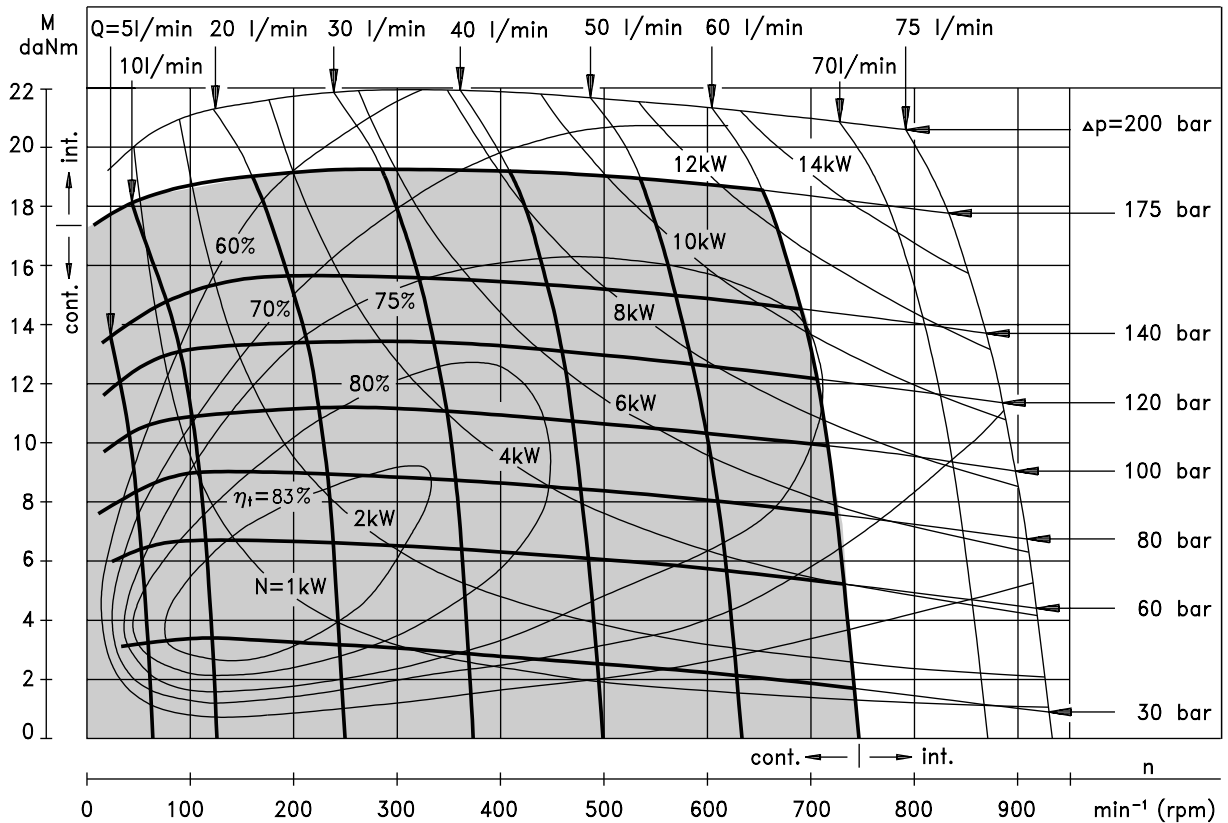

The function diagrams data was collected at back pressure 5 ÷ 10 bar and oil with viscosity of 32 mm²/s at 50° C.

FUNCTION DIAGRAMS

RL 100

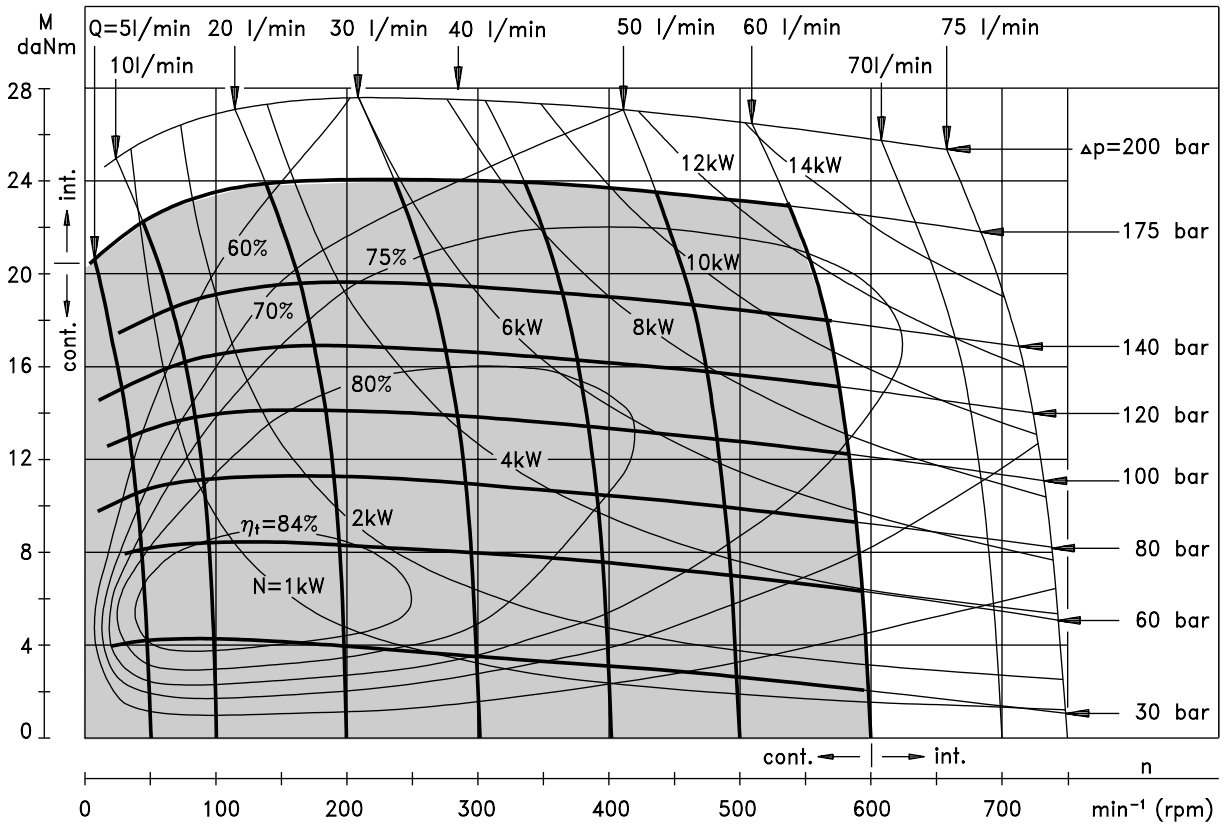

RL 125

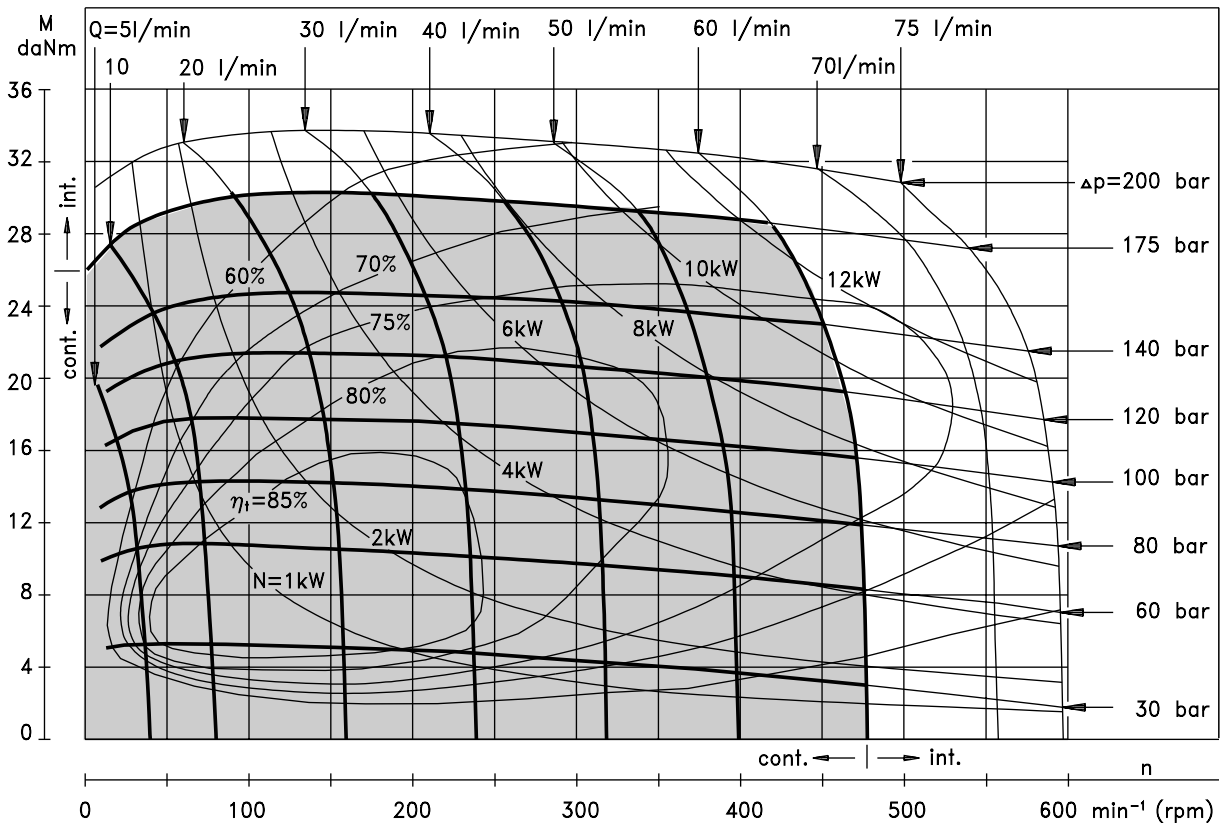

The function diagrams data was collected at back pressure $5 \div 10$ bar and oil with viscosity of $32 \text{ mm}^2/\text{s}$ at 50° C .

FUNCTION DIAGRAMS

RL 160

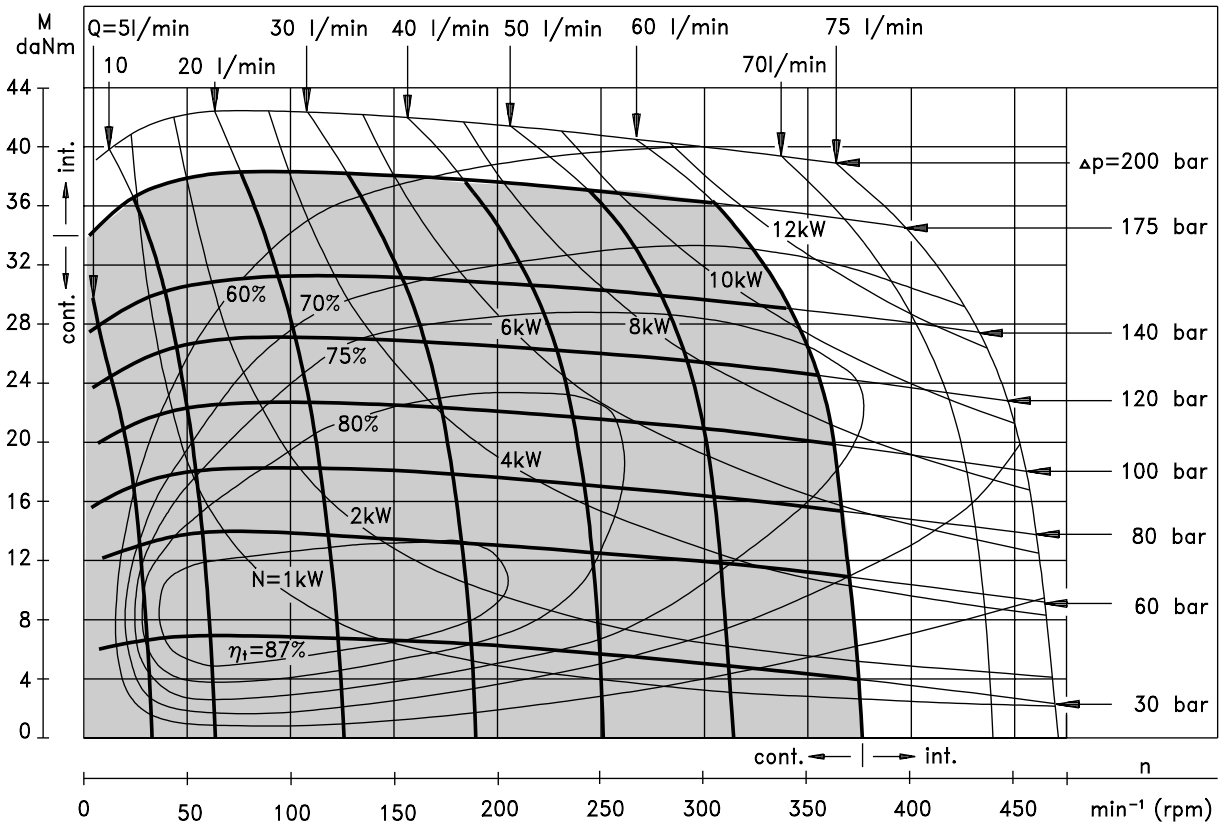

RL 200

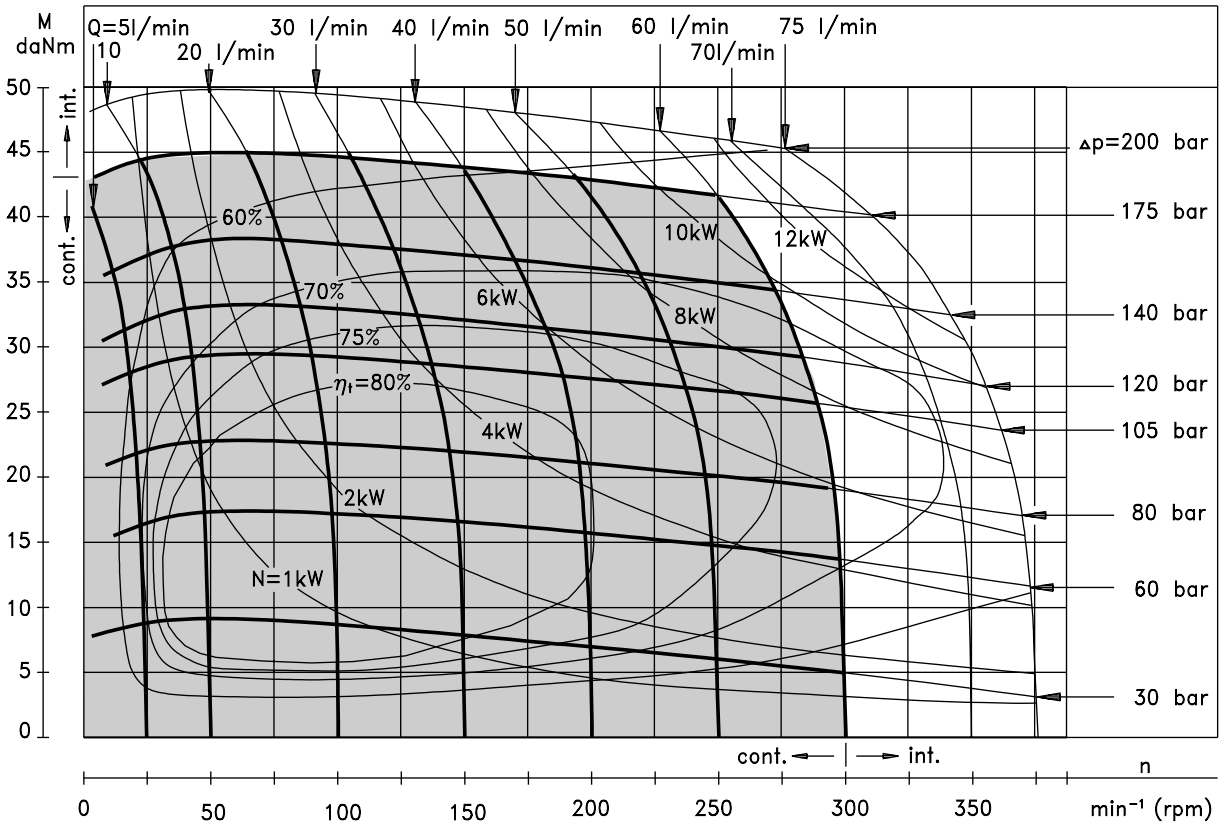

The function diagrams data was collected at back pressure 5 ÷ 10 bar and oil with viscosity of 32 mm²/s at 50° C.

FUNCTION DIAGRAMS

RL 250

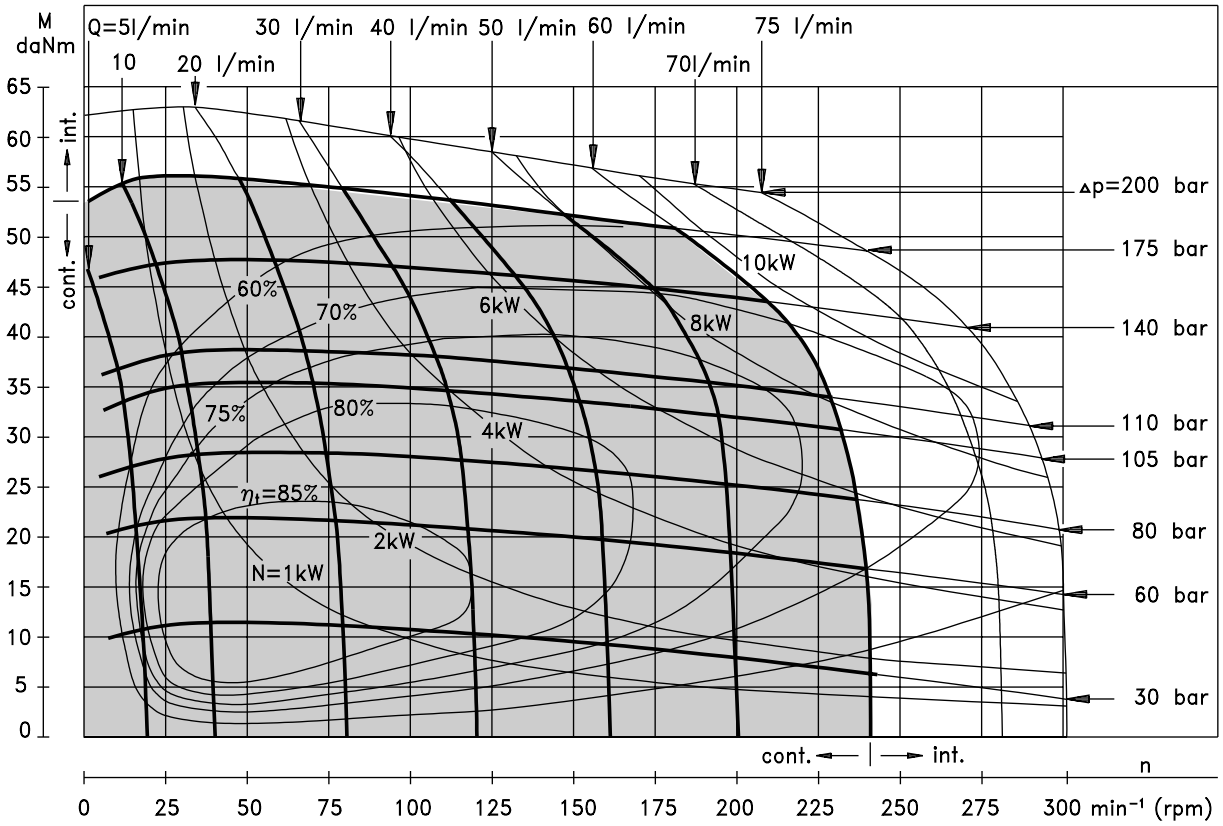

RL 315

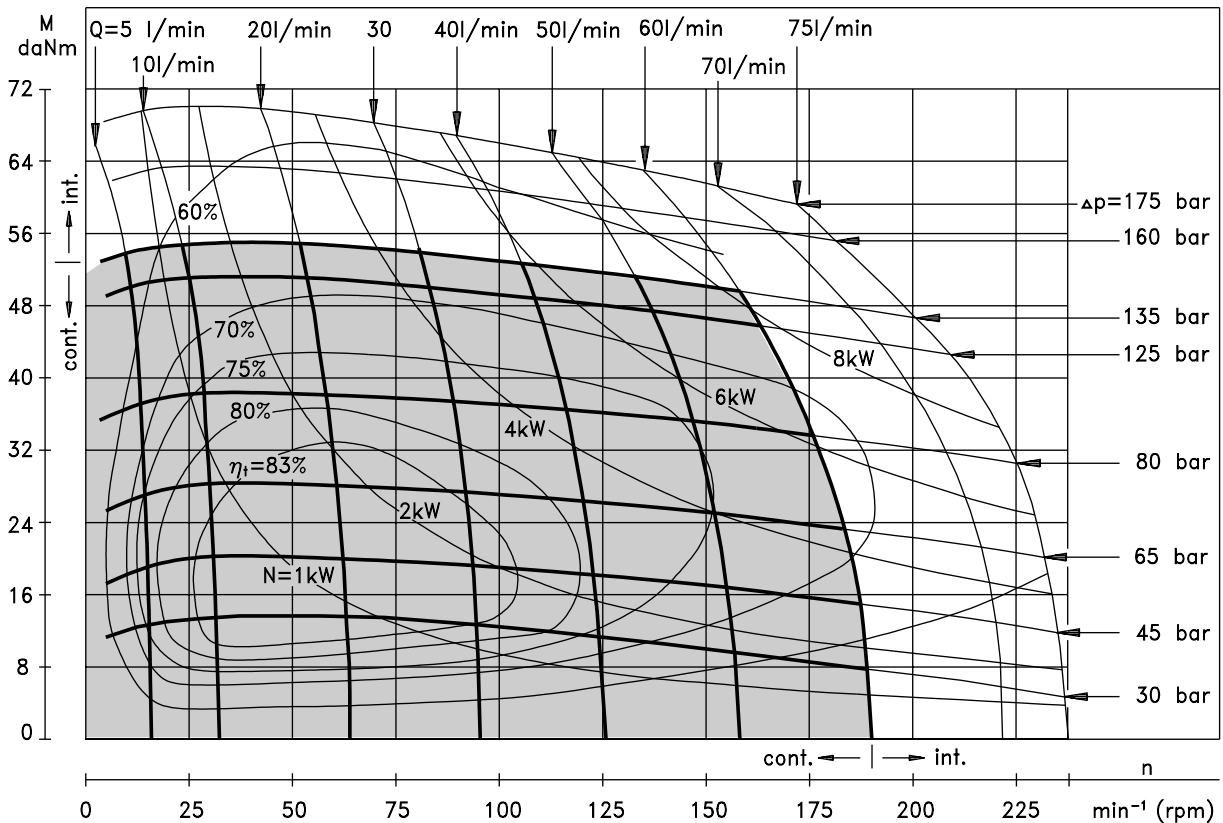

The function diagrams data was collected at back pressure 5 ÷ 10 bar and oil with viscosity of 32 mm²/s at 50° C.

FUNCTION DIAGRAM

RL 400

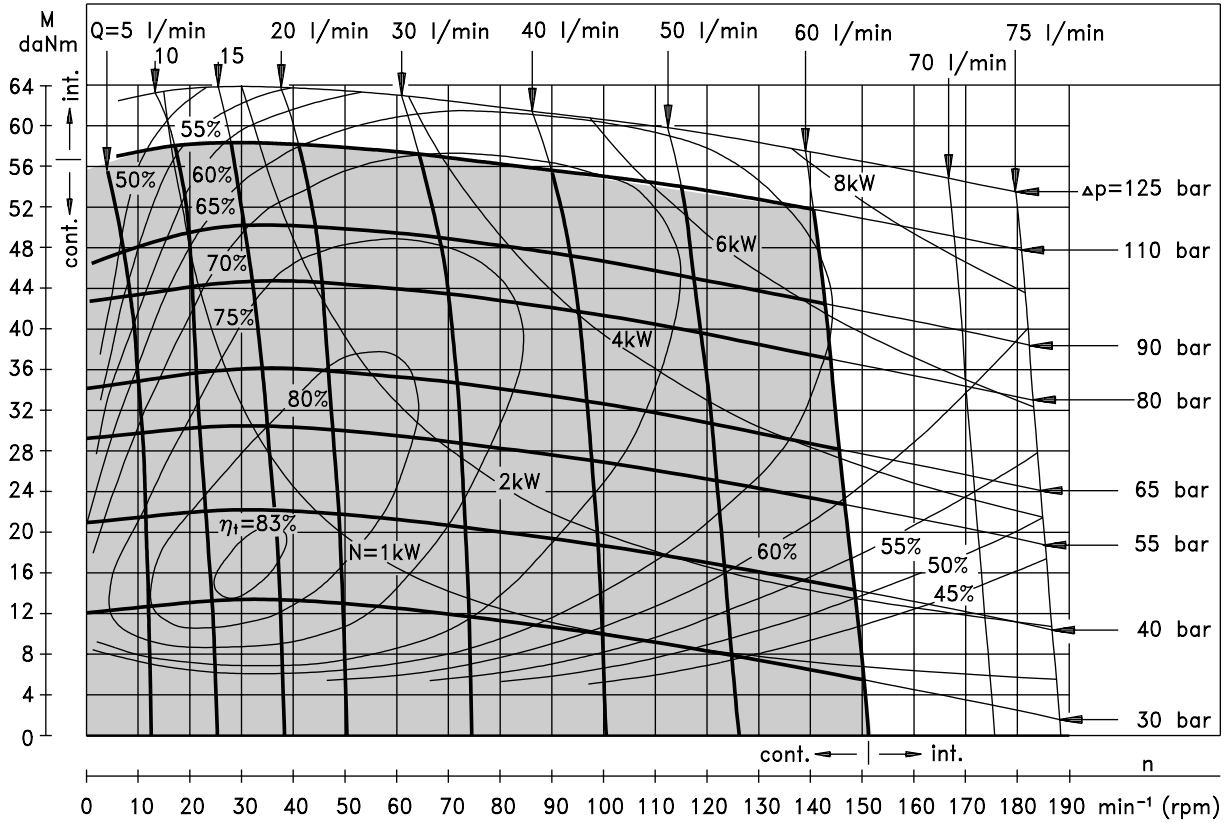

The function diagram data was collected at back pressure $5 \div 10$ bar and oil with viscosity of $32 \text{ mm}^2/\text{s}$ at 50° C .

Permissible Shaft Loads RL

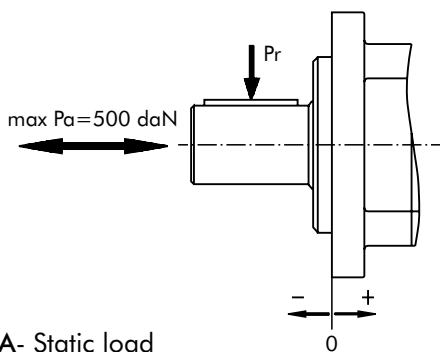

- A- Static load
- B- $Pa = 200 \text{ daN}$
- C- $Pa = 500 \text{ daN}$

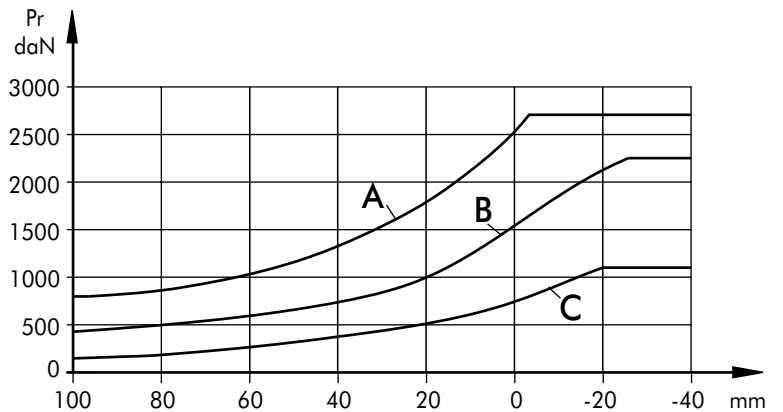

DIMENSIONS AND MOUNTING DATA

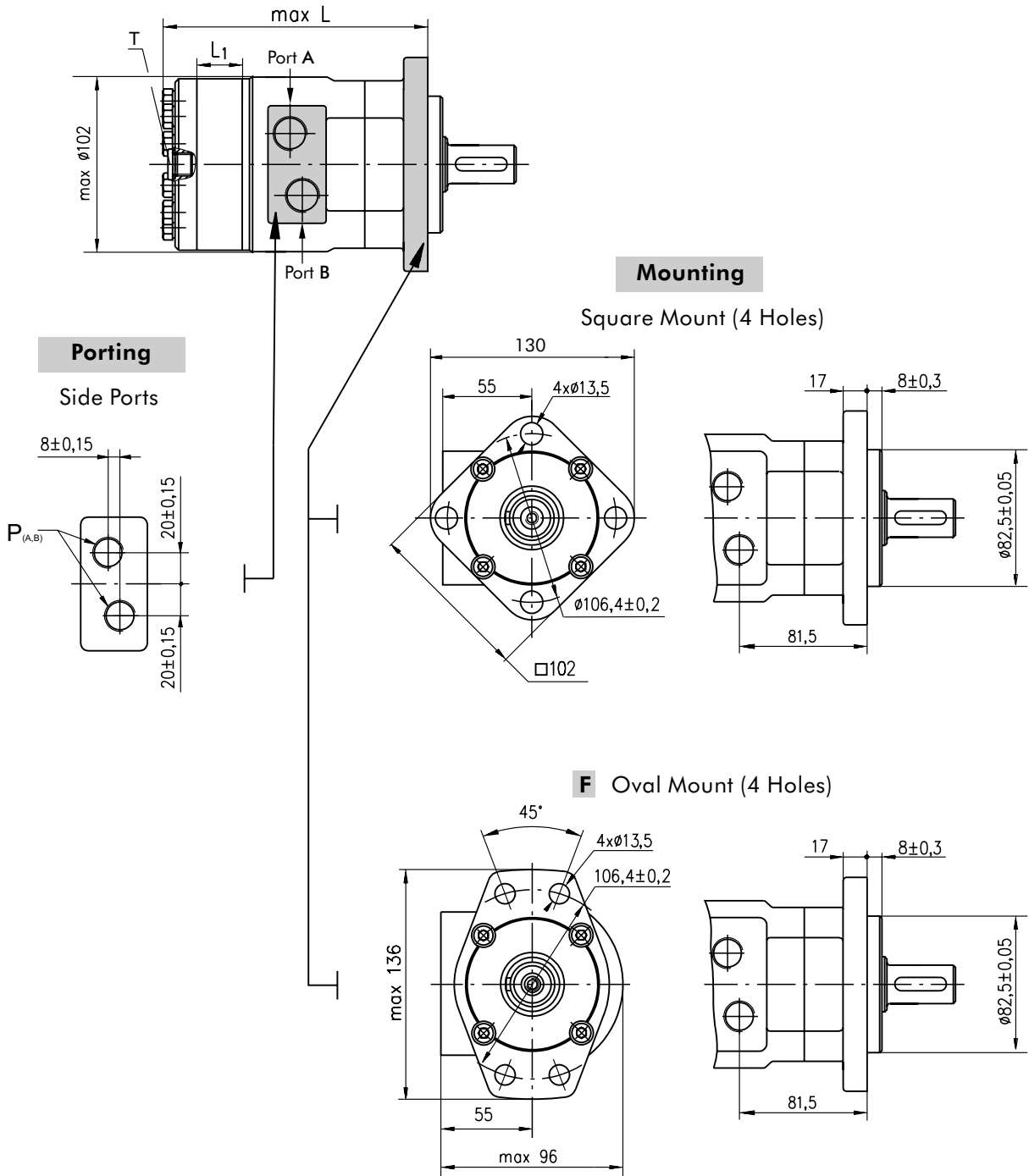

Type	L, mm	L ₁ , mm
RL 50	152	9,0
RL 80	157	14,0
RL 100	160	17,4
RL 125	165	21,8
RL 160	171	27,8
RL 200	178	34,8
RL 250	187	43,5
RL 315	198	54,8
RL 400	212	69,4

P_(A, B): 2xG1/2 or 2xM22x1,5 - 15 mm depth
T : G1/4 or M14x1,5 - 12 mm depth (plugged)

Standard Rotation
 Viewed from Shaft End
 Port A Pressurized - CW
 Port B Pressurized - CCW

Reverse Rotation
 Viewed from Shaft End
 Port A Pressurized - CCW
 Port B Pressurized - CW

SHAFT EXTENSIONS

C - $\varnothing 25$ straight, Parallel key A8x7x30 DIN 6885
Max. Torque 34 daNm

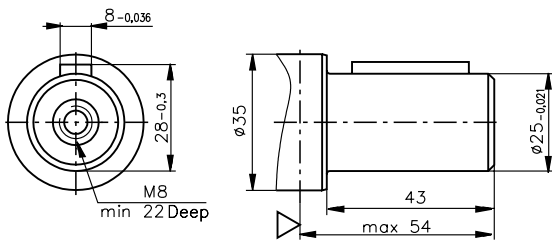

CB - $\varnothing 32$ straight, Parallel key A10x8x40 DIN 6885
Max. Torque 77 daNm

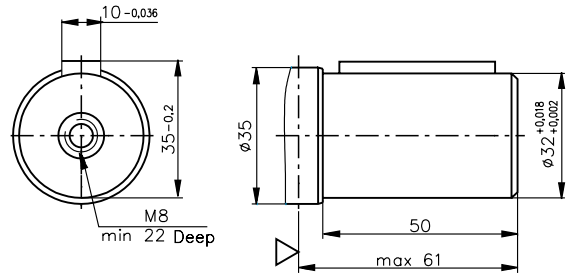

SH - splined, BS 2059 (SAE 6B)
Max. Torque 40 daNm

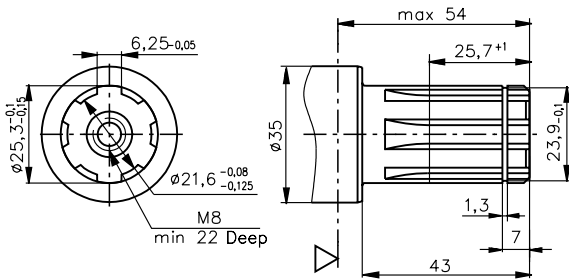

HB - $\varnothing 1\frac{1}{4}$ " splined 14T, DP12/24 ANSI B92.1-1976
Max. Torque 95 daNm

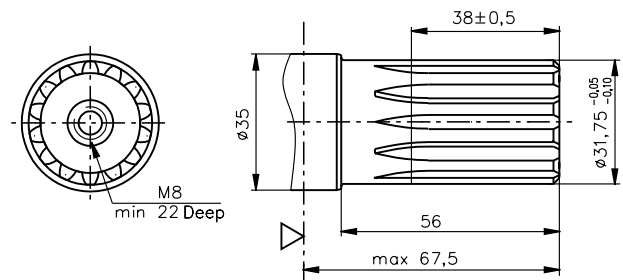

KB - tapered 1:10, woodruff key 6x9 DIN6888
Max. Torque 95 daNm

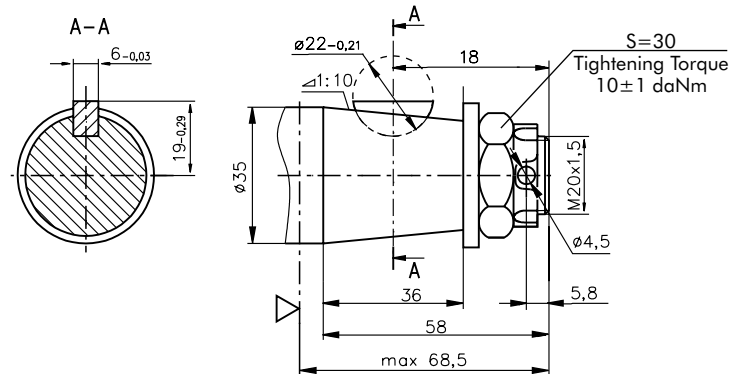

▽- Motor Mounting Surface

ORDER CODE

	1	2	3	4	5	6
RL						

Pos. 1 - Mounting Flange

omit - Square mount, four holes

F - Oval mount, four holes

Pos. 2 - Displacement code

50 - 51,5 [cm³/rev]

80 - 80,3 [cm³/rev]

100 - 99,8 [cm³/rev]

125 - 125,7 [cm³/rev]

160 - 159,6 [cm³/rev]

200 - 199,8 [cm³/rev]

250 - 250,1 [cm³/rev]

315 - 315,7 [cm³/rev]

400 - 397,0 [cm³/rev]

Pos. 3 - Shaft Extensions*

C - ø25 straight, Parallel key A8x7x30 DIN6885

CB - ø32 straight, Parallel key A10x8x40 DIN6885

SH - ø25,3 splined BS 2059 (SAE 6B)

HB - ø1¼" splined 14T ANSI B92.1 - 1976

KB - ø35 tapered 1:10, Woodruff key 6x9 DIN6888

Pos. 4 - Ports

omit - BSPP (ISO 228)

M - Metric (ISO 262)

Pos. 5 - Special Features (see page 53)

Pos. 6 - Design series

omit - Factory specified

NOTES:

* The permissible output torque for shafts must not be exceeded!

The hydraulic motors are mangano-phosphatized as standard.

HYDRAULIC MOTORS RW



APPLICATION

- » Conveyors
- » Feeding mechanism of robots and manipulators
- » Metal working machines
- » Textile machines
- » Machines for agriculture
- » Food industries
- » Grass cutting machinery etc.

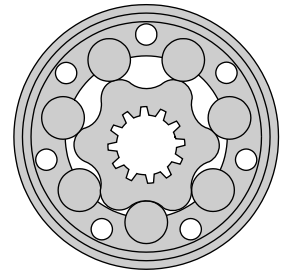

CONTENTS

Specification data	25
Function diagrams	26 ÷ 30
Permissible shaft Seal Pressure ...	30
Dimensions and mounting	31
Permissible shaft loads	31
Shaft extensions	32
Order code	32

OPTIONS

- » Model- Spool valve, roll-gerotor
- » Wheel mount
- » Shafts- straight and tapered
- » Metric and BSPP ports
- » Other special features

GENERAL

Displacement, [cm ³ /rev.]	51,5 ÷ 397
Max. Speed, [RPM]	150 ÷ 775
Max. Torque, [daNm]	10 ÷ 61
Max. Output, [kW]	7 ÷ 13
Max. Pressure Drop, [bar]	110 ÷ 175
Max. Oil Flow, [l/min]	40 ÷ 60
Min. Speed, [RPM]	10
Pressure fluid	Mineral based- HLP(DIN 51524) or HM(ISO 6743/4)
Temperature range, [°C]	-30 ÷ 90
Optimal Viscosity range, [mm ² /s]	20 ÷ 75
Filtration	ISO code 20/16 (Min. recommended fluid filtration of 25 micron)

Oil flow in drain line

Pressure drop (bar)	Viscosity (mm ² /s)	Oil flow in drain line (l/min)
100	20	2,5
	35	1,8
140	20	3,5
	35	2,8

Pressure Losses

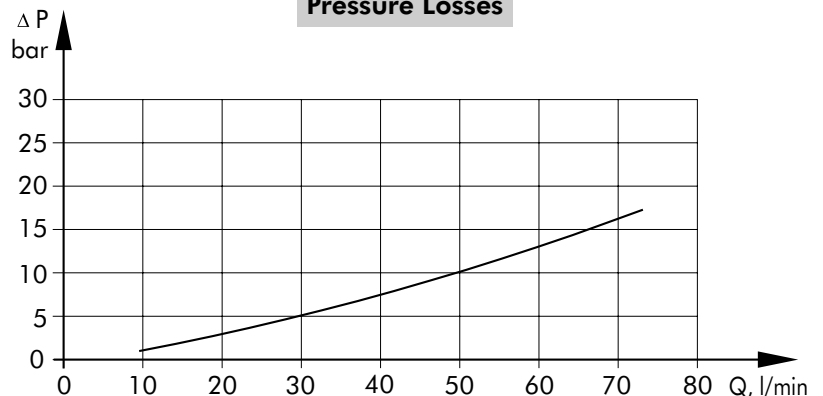

SPECIFICATION DATA

Type	RW									
	50	80	100	125	160	200	250	315	400	
Displacement, [cm ³ /rev.]	51,5	80,3	99,8	125,7	159,6	199,8	250,1	315,7	397	
Max. Speed, [RPM]	cont.	775	750	600	475	375	300	240	190	150
	int.*	970	940	750	600	470	375	300	240	190
Max. Torque [daNm]	cont.	10	20	24	30	39	45	54	55	61
	int.*	13	22	28	34	43	50	61	69	69
	peak**	17	27	32	37	46	56	71	84	87
Max. Output, [kW]	cont.	7	12,5	13	12,5	11,5	11	10	9	7,8
	int.*	8,5	15	15	14,5	14	13	12	10	10,6
Max. Pressure	cont.	140	175	175	175	175	175	175	135	110
Drop [bar]	int.*	175	200	200	200	200	200	200	175	140
	peak**	225	225	225	225	225	225	225	210	175
Max. Oil Flow [l/min]	cont.	40	60	60	60	60	60	60	60	60
	int.*	50	75	75	75	75	75	75	75	75
Max. Inlet Pressure [bar]	cont.	175	175	175	175	175	175	175	175	175
	int.*	200	200	200	200	200	200	200	200	200
	peak**	225	225	225	225	225	225	225	225	225
Max. Return Pressure with Drain Line [bar]	cont.	175	175	175	175	175	175	175	175	175
	int.*	200	200	200	200	200	200	200	200	200
	peak**	225	225	225	225	225	225	225	225	225
Max. Starting Pressure with Unloaded Shaft, [bar]		10	10	10	9	7	5	4	3	3
Min. Starting Torque [daNm]	at max. press. drop cont.	8	15	20	25	32	41	50	50	50
	at max. press. drop int.*	10	17	23	28	37	46	55	66	61
Min. Speed***, [RPM]		10	10	10	10	10	10	10	10	10
Weight, avg. [kg]		10,4	10,5	10,6	10,8	11,1	11,6	12,1	12,6	13,3

* Intermittent operation: the permissible values may occur for max. 10% of every minute.

** Peak load: the permissible values may occur for max. 1% for every minute.

*** For speeds of 10 RPM or lower, consult factory or your regional manager.

1. Intermittent speed and intermittent pressure drop must not occur simultaneously!

2. Recommended filtration is per ISO cleanliness code 20/16. A nominal filtration of 25 micron or better.

3. Recommended using a premium quality, anti-wear type mineral based hydraulic oil HLP(DIN51524) or HM (ISO 6743/4).

If using synthetic fluids consult the factory for alternative seal materials.

4. Recommended minimum oil viscosity 13 mm²/s at operating temperatures.

5. Recommended maximum system operating temperature - 82°C.

6. To assure optimum motor life fill with fluid prior to loading and run at moderate load and speed for 10-15 min.

FUNCTION DIAGRAMS

RW 50

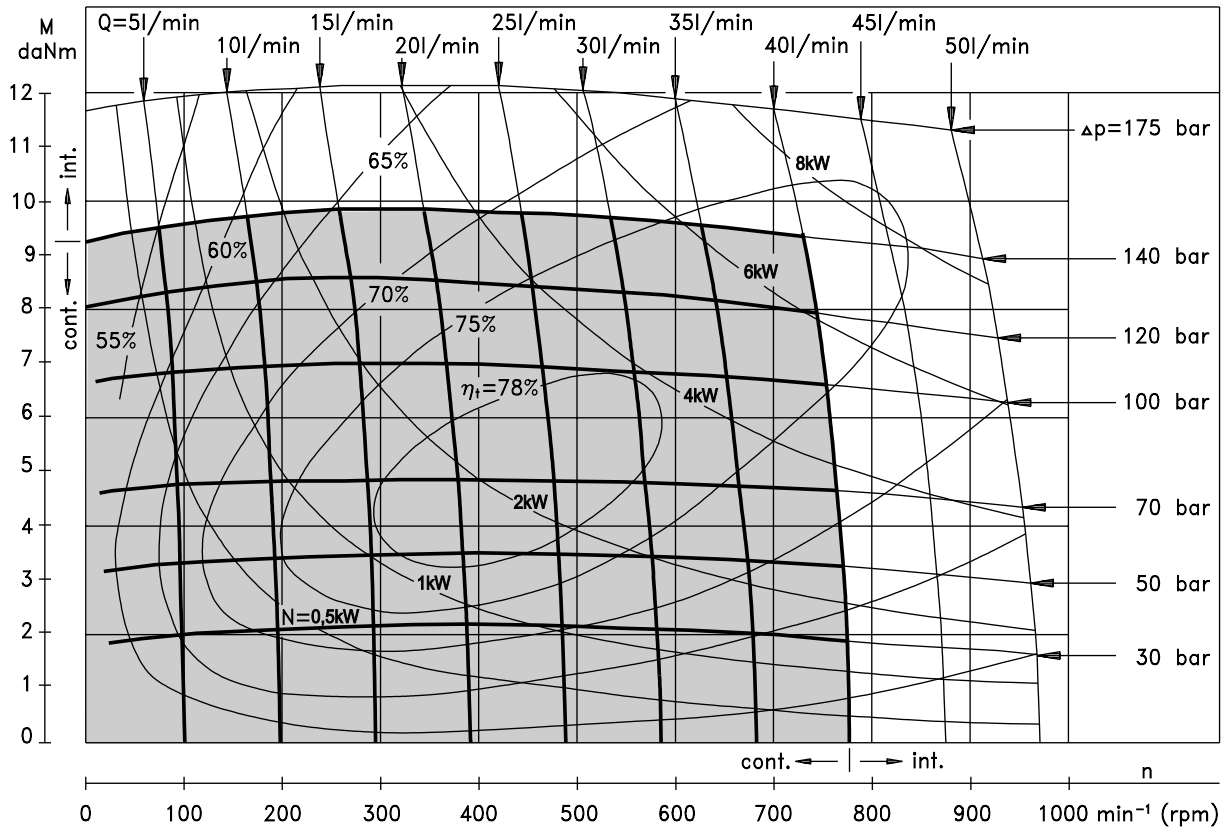

RW 80

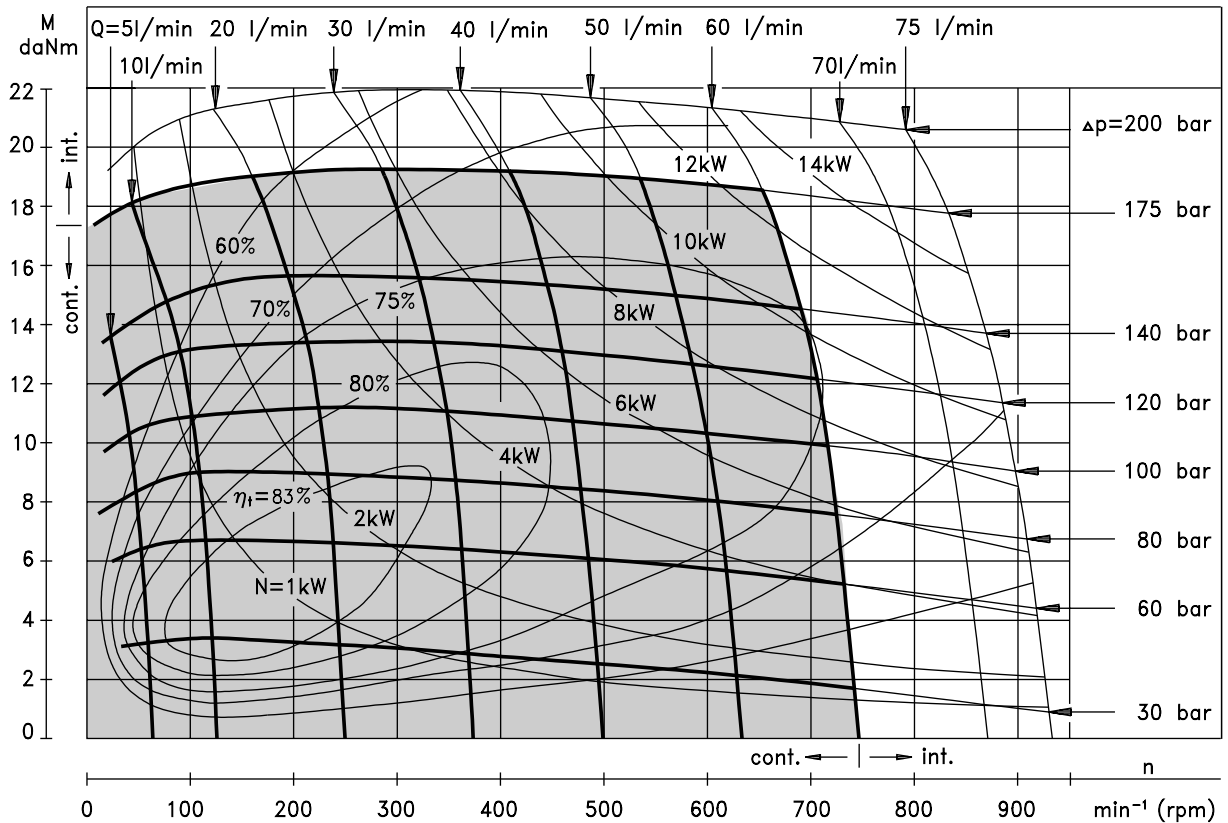

The function diagrams data was collected at back pressure 5 ÷ 10 bar and oil with viscosity of 32 mm²/s at 50° C.

FUNCTION DIAGRAMS

RW 100

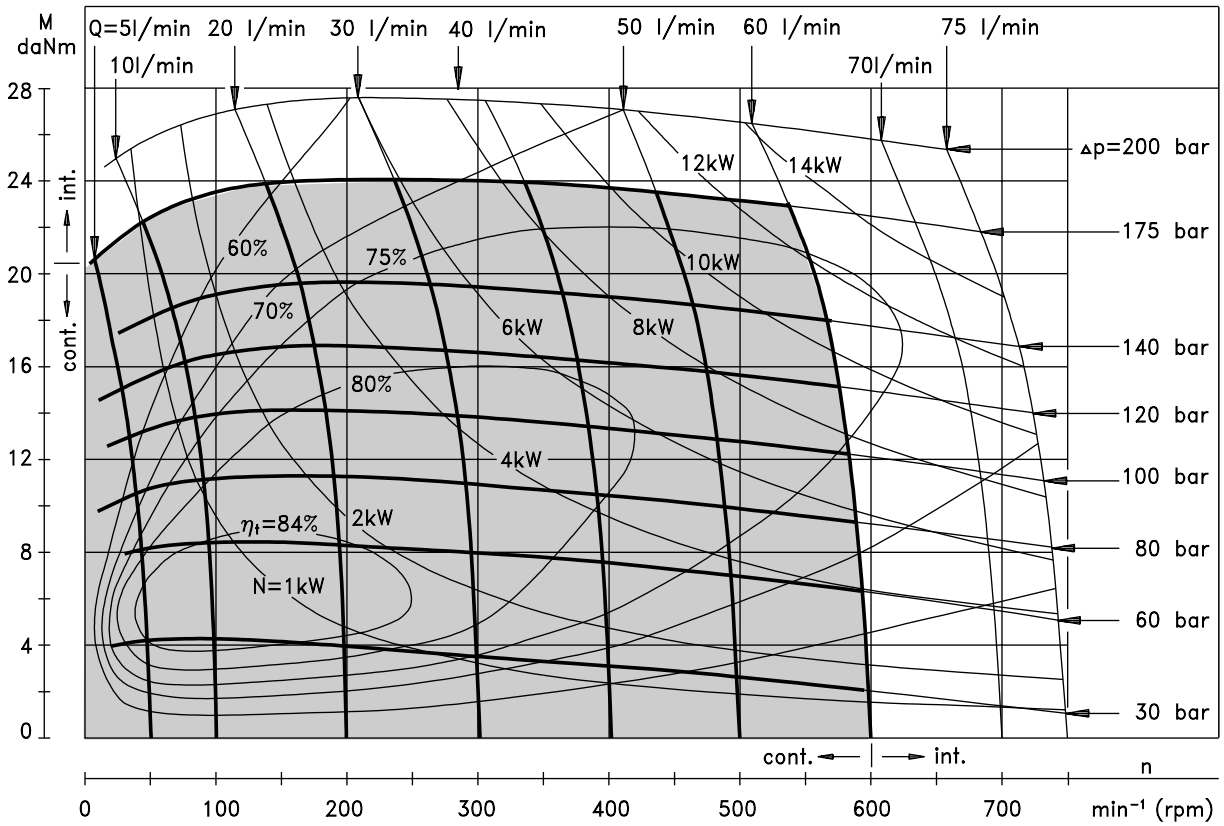

RW 125

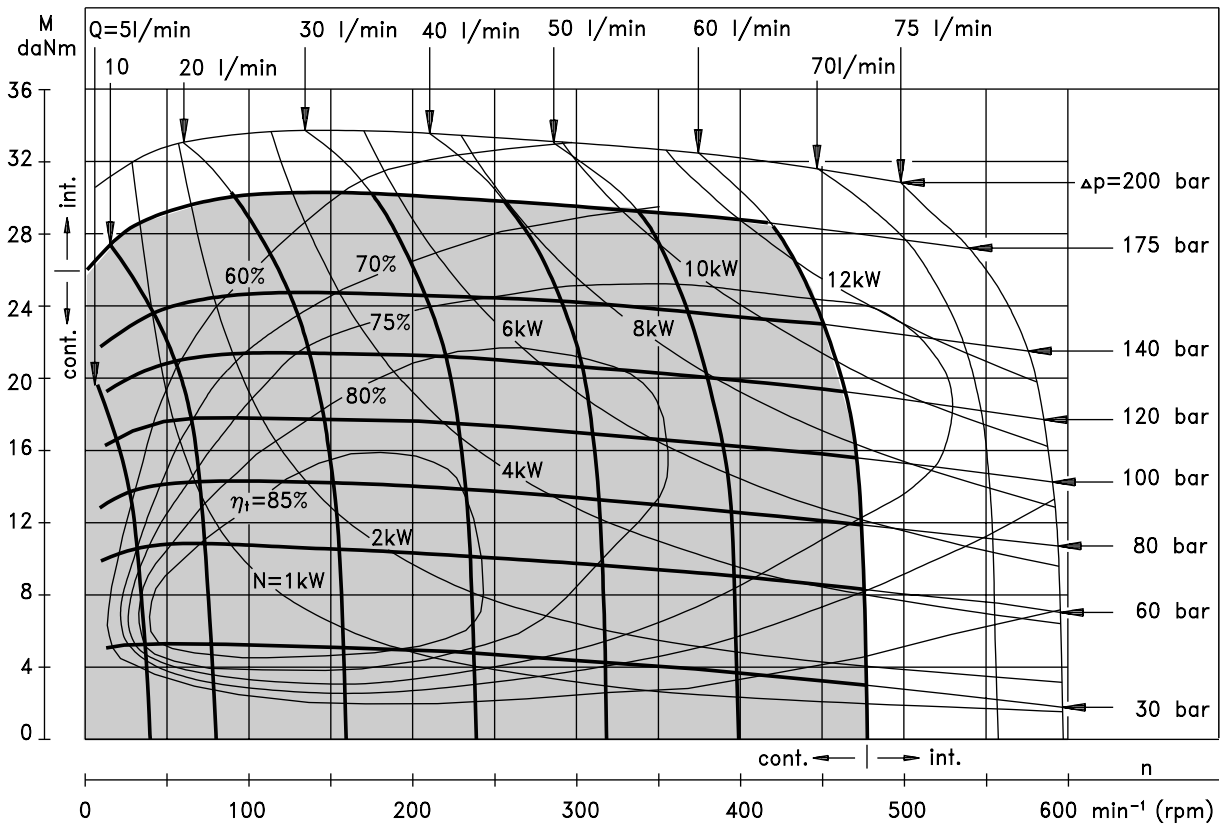

The function diagrams data was collected at back pressure $5 \div 10$ bar and oil with viscosity of $32 \text{ mm}^2/\text{s}$ at 50° C .

FUNCTION DIAGRAMS

RW 160

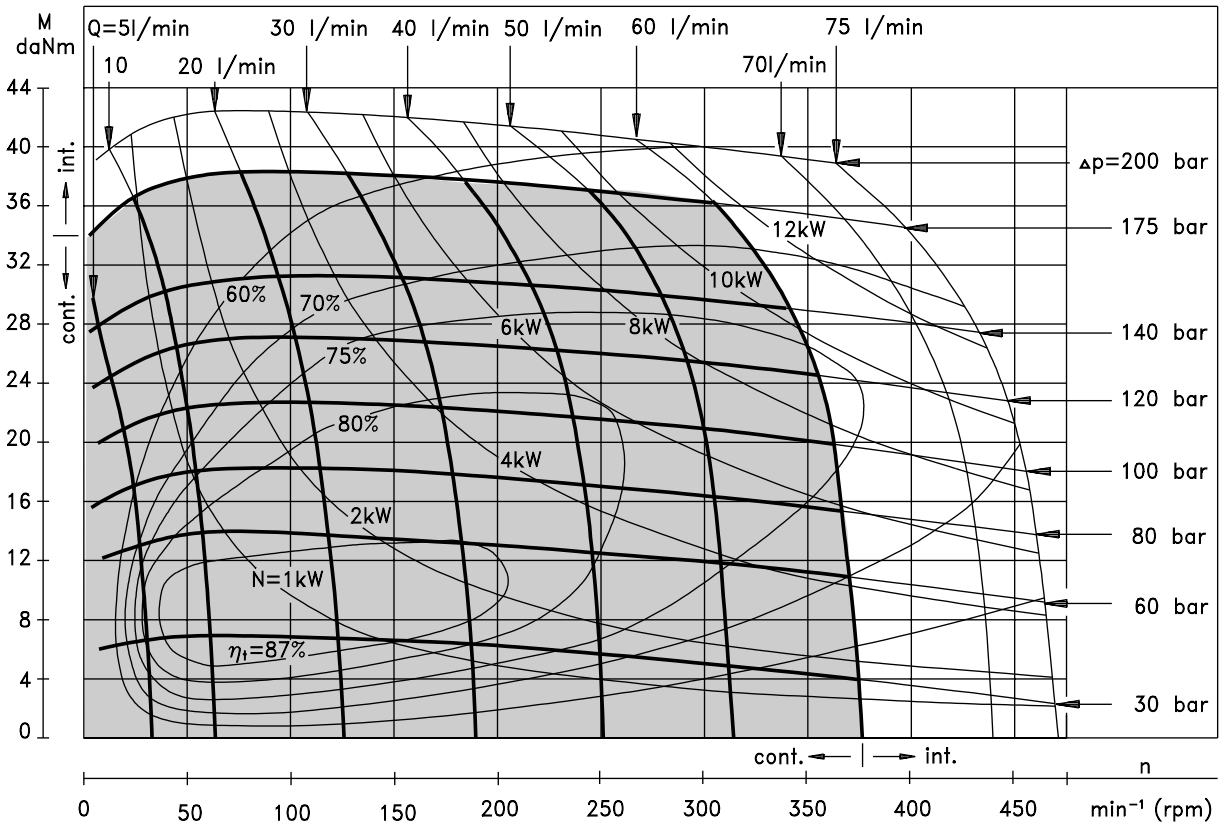

RW 200

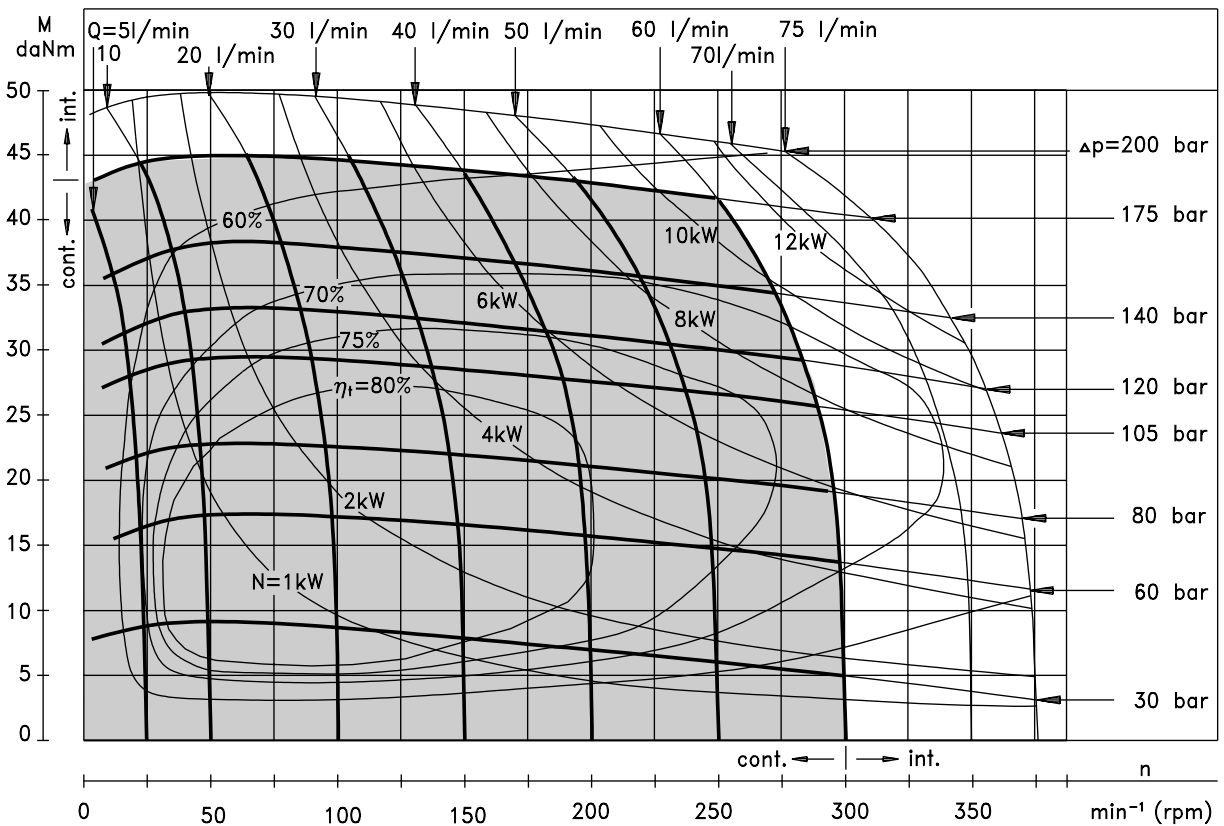

The function diagrams data was collected at back pressure $5 \div 10$ bar and oil with viscosity of $32 \text{ mm}^2/\text{s}$ at 50°C .

FUNCTION DIAGRAMS

RW 250

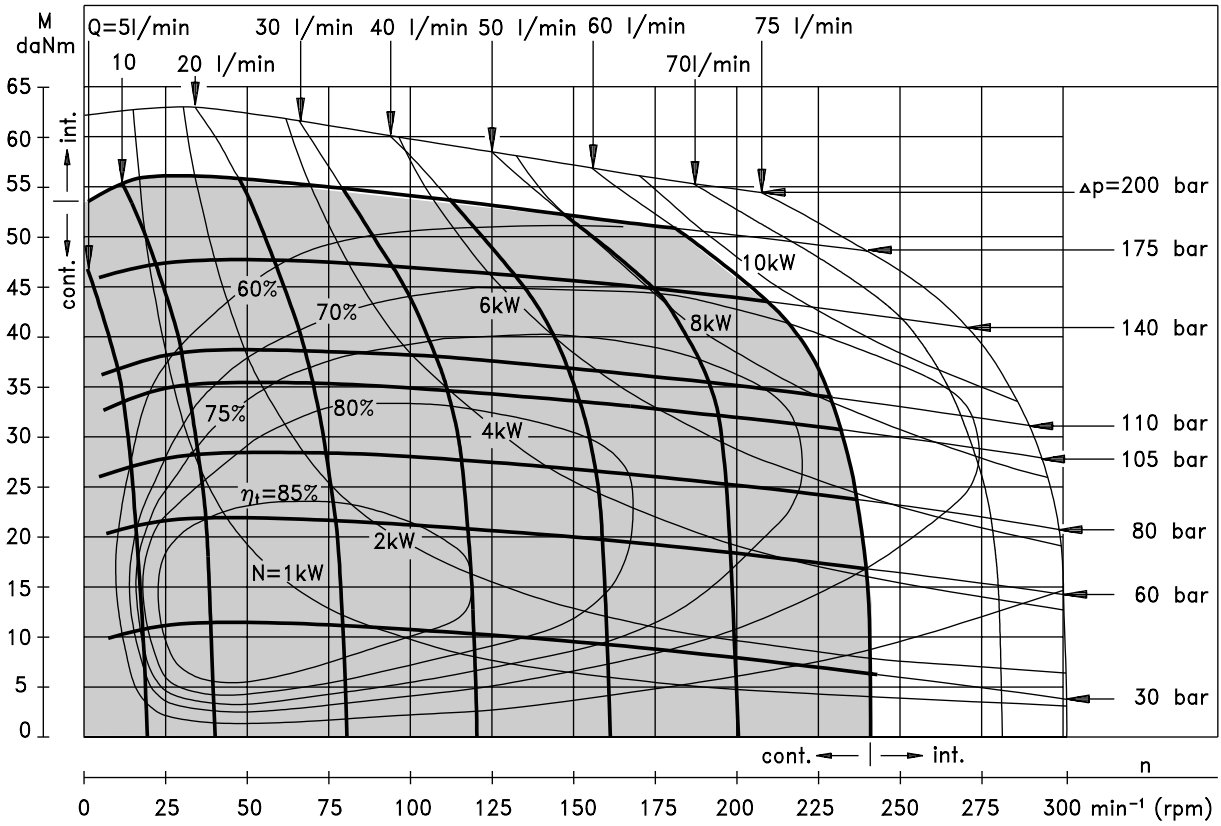

RW 315

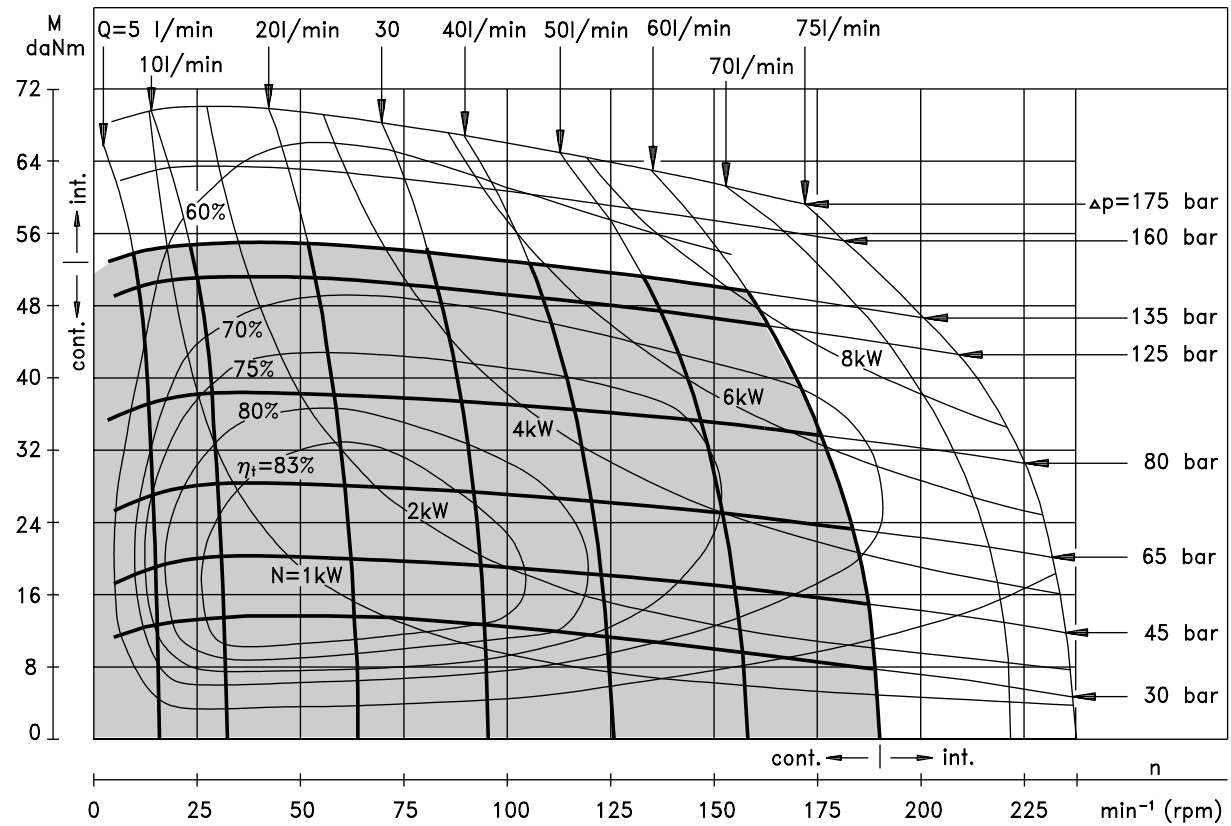

The function diagrams data was collected at back pressure 5 ÷ 10 bar and oil with viscosity of 32 mm²/s at 50° C.

FUNCTION DIAGRAM

RW 400

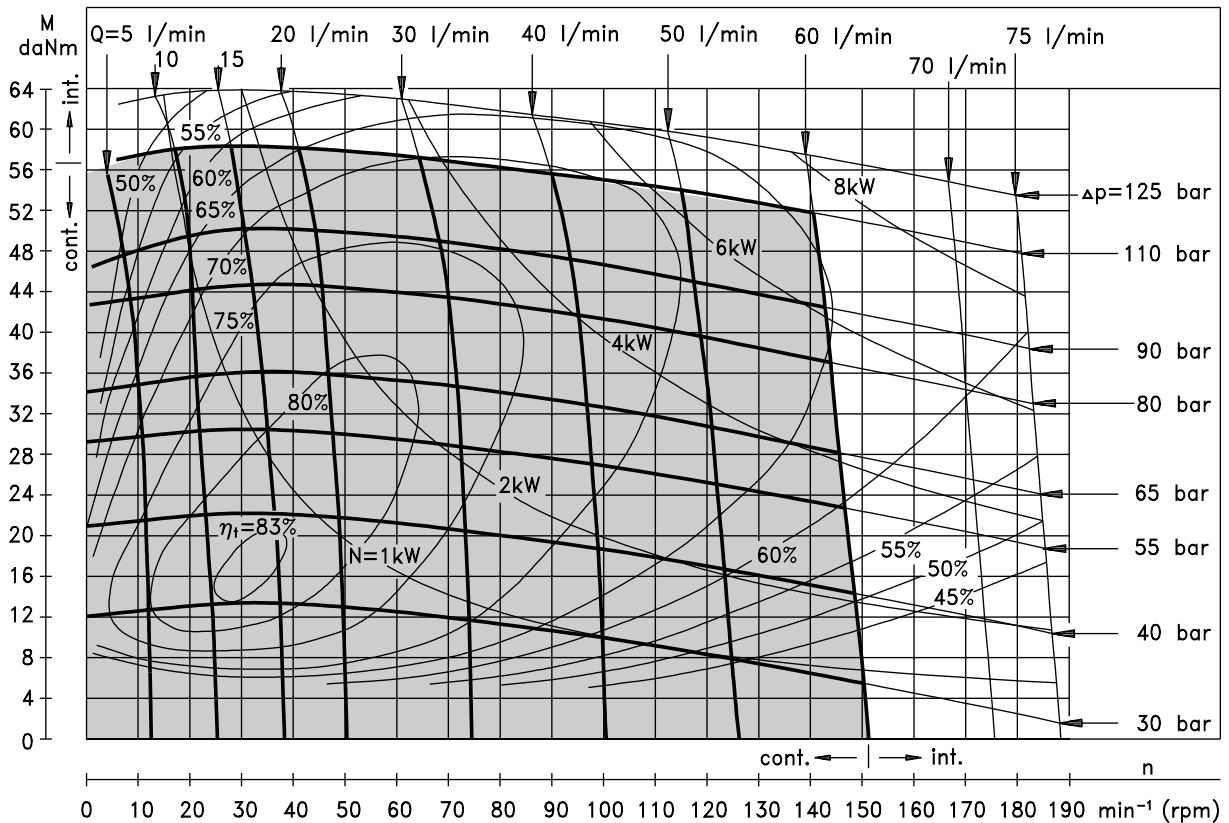

The function diagram data was collected at back pressure 5 ÷ 10 bar and oil with viscosity of 32 mm²/s at 50° C.

MAX. PERMISSIBLE SHAFT SEAL PRESSURE

RW...1 motors without drain connection:

The shaft seal pressure never exceeds the pressure in the return line.

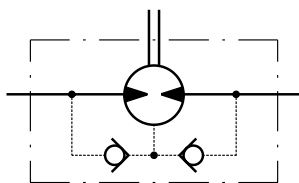

RW... motors with drain connection:

The shaft seal pressure equals the pressure in the drain line.

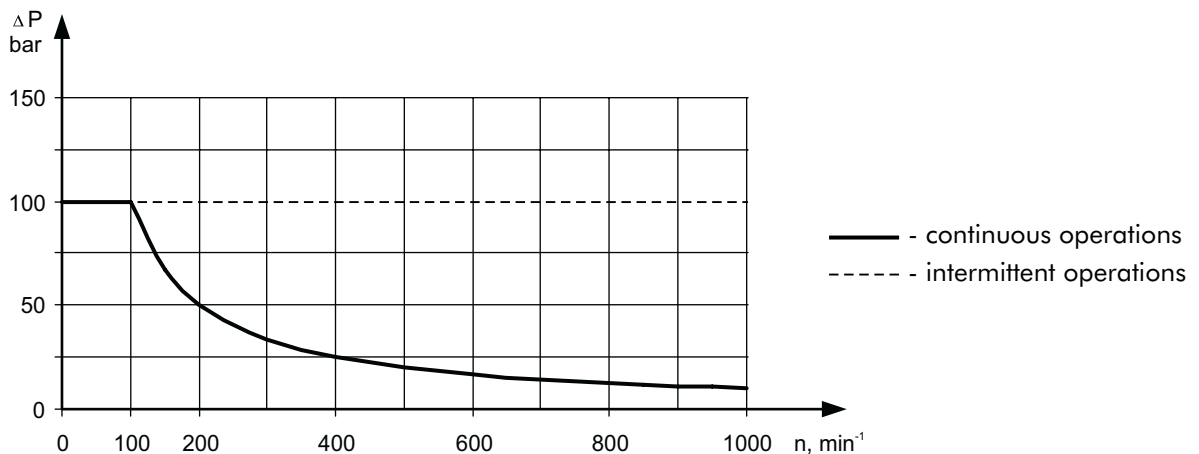
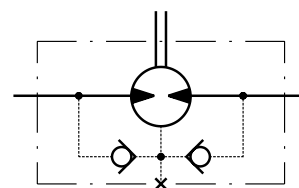

DIMENSIONS AND MOUNTING DATA

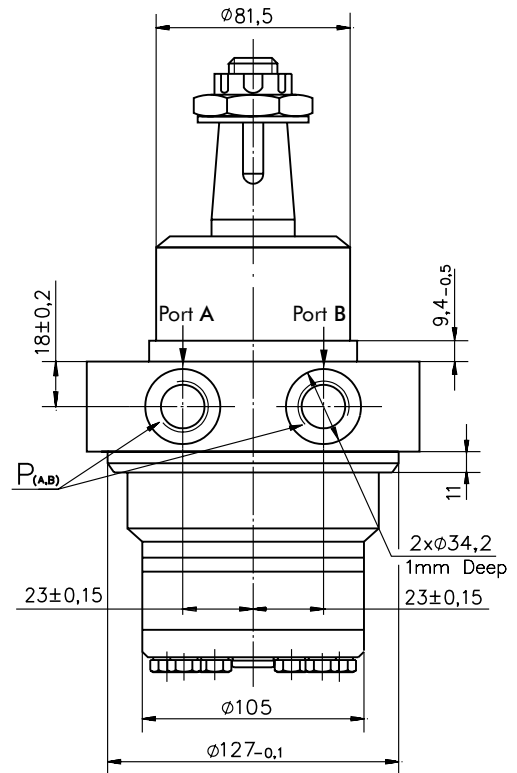
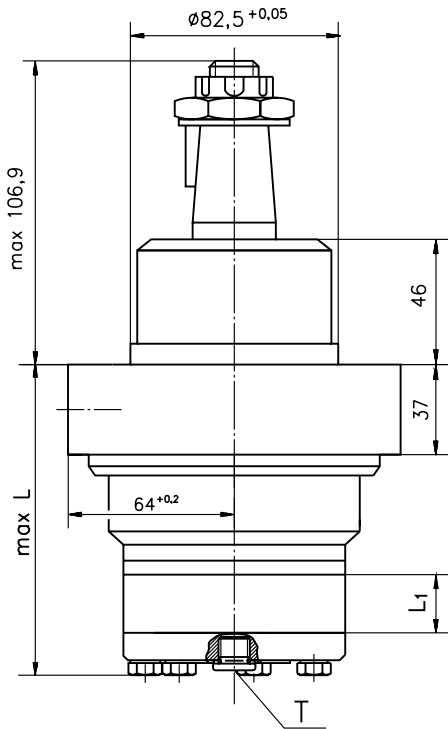

P_(A,B): 2xG1/2 or 2xM22x1,5 - 15 mm depth

T : G1/4 or M14x1,5 - 12 mm depth (plugged)

Standard Rotation

Viewed from Shaft End

Port A Pressurized - CW

Port B Pressurized - CCW

Reverse Rotation

Viewed from Shaft End

Port A Pressurized - CCW

Port B Pressurized - CW

Permissible Shaft Loads

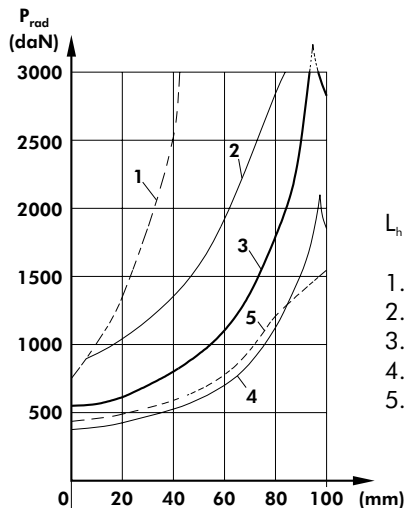

$L_h = 2500 \text{ h}$

1. Permissible radial shaft load
2. Drawing by $n = 50 \text{ min}^{-1}$
3. Drawing by $n = 200 \text{ min}^{-1}$
4. Drawing by $n = 800 \text{ min}^{-1}$
5. Drawing by $n = 200 \text{ min}^{-1}$ and $P_o \text{ max} = 500 \text{ daN}$

$P_o \text{ max} = 500 \text{ daN}$

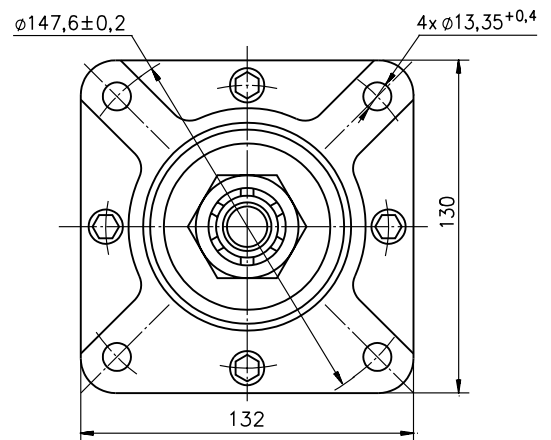
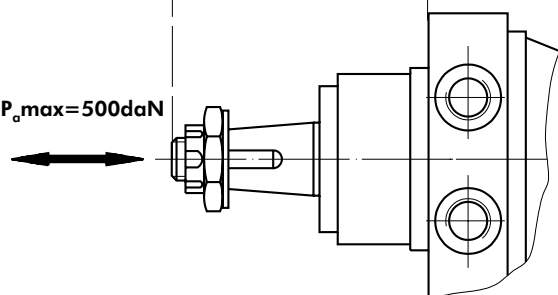

Type	L, mm	L ₁ , mm
RW 50	111	9,0
RW 80	116	14,0
RW 100	120	17,4
RW 125	124	21,8
RW 160	130	27,8
RW 200	137	34,8
RW 250	146	43,5
RW 315	157	54,8
RW 400	172	69,4

SHAFT EXTENSIONS

CB - $\varnothing 32$ straight, Parallel key A10x8x45 DIN 6885
Max. Torque 77 daNm

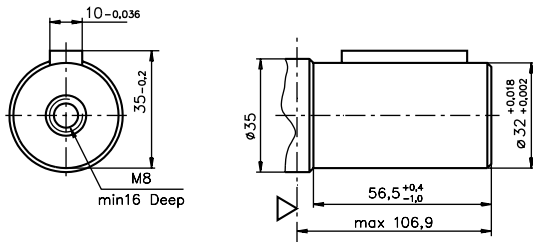

KB - tapered 1:10, Parallel key B6x6x20 DIN 6885
Max. Torque 77 daNm

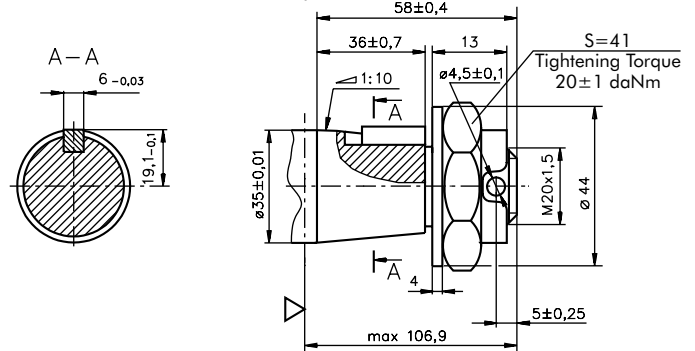

OB - tapered 1:8 SAEJ 501, Parallel key $\frac{5}{16} \times \frac{5}{16} \times 1\frac{1}{4}$ " BS46
Max. Torque 77 daNm

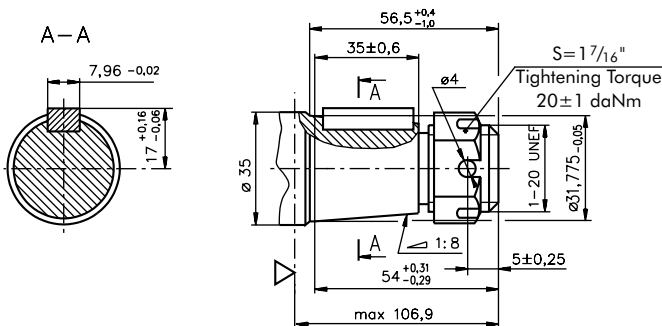

▽ - Motor Mounting Surface

ORDER CODE

	1	2	3	4	5	6
R W						

Pos. 1 - Displacement code

50	- 51,5 [cm ³ /rev]
80	- 80,3 [cm ³ /rev]
100	- 99,8 [cm ³ /rev]
125	- 125,7 [cm ³ /rev]
160	- 159,6 [cm ³ /rev]
200	- 199,8 [cm ³ /rev]
250	- 250,1 [cm ³ /rev]
315	- 315,7 [cm ³ /rev]
400	- 397,0 [cm ³ /rev]

Pos. 2 - Shaft Extensions*

CB	- $\varnothing 32$ straight, Parallel key A10x8x45 DIN6885
KB	- $\varnothing 35$ tapered 1:10, Parallel key B6x6x20 DIN6885
OB	- $\varnothing 1\frac{1}{4}$ tapered 1:8, Parallel key $\frac{5}{16} \times \frac{5}{16} \times 1\frac{1}{4}$ " BS46

Pos. 3 - Drain Port

omit	- with drain port
1	- without drain port

Pos. 4 - Ports

omit	- BSPP (ISO 228)
M	- Metric (ISO 262)

Pos. 5 - Special Features (see page 53)

Pos. 6 - Design Series

omit	- Factory specified
------	---------------------

NOTE: * The permissible output torque for shafts must not be exceeded!

The hydraulic motors are mangano-phosphatized as standard.

HYDRAULIC MOTORS HW



APPLICATION

- » Conveyors
- » Feeding mechanism of robots and manipulators
- » Metal working machines
- » Textile machines
- » Machines for agriculture
- » Food industries
- » Grass cutting machinery etc.

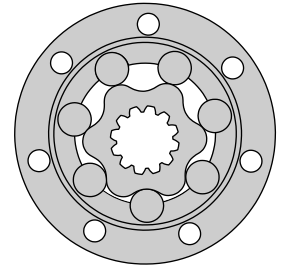

CONTENTS

Specification data34 ÷ 35
 Permissible shaft Seal Pressure ... 38
 Dimensions and mounting 36
 Permissible shaft loads 38
 Shaft extensions 37
 Order code 39

OPTIONS

- » Model- Spool valve, roll-gerotor
- » Wheel mount
- » Shafts- straight, splined and tapered
- » BSPP ports
- » Other special features

GENERAL

Displacement, [cm ³ /rev.]	126 ÷ 550
Max. Speed, [RPM]	136 ÷ 380
Max. Torque, [daNm]	35 ÷ 96
Max. Output, [kW]	9 ÷ 17,6
Max. Pressure Drop, [bar]	125 ÷ 205
Max. Oil Flow, [l/min]	45 ÷ 75
Min. Speed, [RPM]	10
Pressure fluid	Mineral based- HLP(DIN 51524) or HM(ISO 6743/4)
Temperature range, [°C]	-30 ÷ 90
Optimal Viscosity range, [mm ² /s]	20 ÷ 75
Filtration	ISO code 20/16 (Min. recommended fluid filtration of 25 micron)

Oil flow in drain line

Pressure drop (bar)	Viscosity (mm ² /s)	Oil flow in drain line (l/min)
100	20	2,5
	35	1,8
140	20	3,5
	35	2,8

Pressure Losses



SPECIFICATION DATA

Type	HW							
	125	160	200	235	250	300	315	
Displacement, [cm ³ /rev.]	126	157,8	201,3	235,3	252	300	314,9	
Max. Speed, [RPM]	cont.	357	380	348	298	298	250	238
	int.*	476	475	422	361	357	300	286
Max. Torque [daNm]	cont.	35	44	55	64,5	69	81	85
	int.*	38,5	48	60	70	75	89	93
Max. Output, [kW]	cont.	16,2	17,6	17,4	17	16,8	16,5	16,4
	int.*	19,8	21,6	19,6	19,2	18,7	18,7	18,7
Max. Pressure Drop, [bar]	cont.	205	205	205	205	205	205	205
	int.*	225	225	225	225	225	225	225
Max. Oil Flow [l/min]	cont.	45	60	70	70	75	75	75
	int.*	60	75	85	85	90	90	90
Max. Inlet Pressure, [bar]	cont.	210	210	210	210	210	210	210
	int.*	250	250	250	250	250	250	250
Max. Starting Pressure with Unloaded Shaft, [bar]		10	10	10	10	10	10	10
Min. Starting Torque [daNm]	at max. press. drop cont.	28,7	36	41,5	52,8	56,5	66,4	69,7
	at max. press. drop int.*	31,5	39,3	49,2	57,4	61,5	72,9	76,2
Min. Speed**, [RPM]		10	10	10	10	10	10	10
Weight, avg. [kg]		14,3	14,6	15,3	15,7	15,9	16,3	16,5

* Intermittent operation: the permissible values may occur for max. 10% of every minute.

** For speeds of 10 RPM or lower, consult factory or your regional manager.

1. Intermittent speed and intermittent pressure drop must not occur simultaneously!
2. Recommended filtration is per ISO cleanliness code 20/16. A nominal filtration of 25 micron or better.
3. Recommended using a premium quality, anti-wear type mineral based hydraulic oil HLP(DIN51524) or HM (ISO 6743/4).
If using synthetic fluids consult the factory for alternative seal materials.
4. Recommended minimum oil viscosity 13 mm²/s at operating temperatures.
5. Recommended maximum system operating temperature - 82°C.
6. To assure optimum motor life fill with fluid prior to loading and run at moderate load and speed for 10-15 min.

SPECIFICATION DATA

Type	HW							
	350	370	400	470	500	535	550	
Displacement, [cm ³ /rev.]	347,8	369,2	396,8	470,6	502,4	535	550	
Max. Speed, [RPM]	cont.	216	203	189	159	149	140	136
	int.*	259	244	227	191	179	168	164
Max. Torque [daNm]	cont.	94	96	96	92	91	90	89
	int.*	102	105	98	101	101	104	103
Max. Output, [kW]	cont.	16,5	13,2	12,5	10,6	10,8	9,4	9,0
	int.*	18,7	17,3	16,7	13,6	13,9	12,8	12,4
Max. Pressure Drop, [bar]	cont.	205	200	185	150	140	130	125
	int.*	225	225	190	165	155	150	145
Max. Oil Flow [l/min]	cont.	75	75	75	75	75	75	75
	int.*	90	90	90	90	90	90	90
Max. Inlet Pressure, [bar]	cont.	210	210	210	210	210	210	210
	int.*	250	250	250	250	250	250	250
Max. Starting Pressure with Unloaded Shaft, [bar]		10	10	10	10	10	10	10
Min. Starting Torque [daNm]	at max. press. drop cont.	77	79,5	78,7	75,4	74,6	73,8	72,9
	at max. press. drop int.*	83,6	86	80,3	82,8	82,8	85,2	84,4
Min. Speed**, [RPM]		8	8	8	8	8	5	5
Weight, avg. [kg]		16,9	17,1	17,5	18,3	18,6	19,0	19,1

* Intermittent operation: the permissible values may occur for max. 10% of every minute.

** For speeds of 10 RPM or lower, consult factory or your regional manager.

1. Intermittent speed and intermittent pressure drop must not occur simultaneously!
2. Recommended filtration is per ISO cleanliness code 20/16. A nominal filtration of 25 micron or better.
3. Recommended using a premium quality, anti-wear type mineral based hydraulic oil HLP(DIN51524) or HM (ISO 6743/4).
If using synthetic fluids consult the factory for alternative seal materials.
4. Recommended minimum oil viscosity 13 mm²/s at operating temperatures.
5. Recommended maximum system operating temperature - 82°C.
6. To assure optimum motor life fill with fluid prior to loading and run at moderate load and speed for 10-15 min.

DIMENSIONS AND MOUNTING DATA

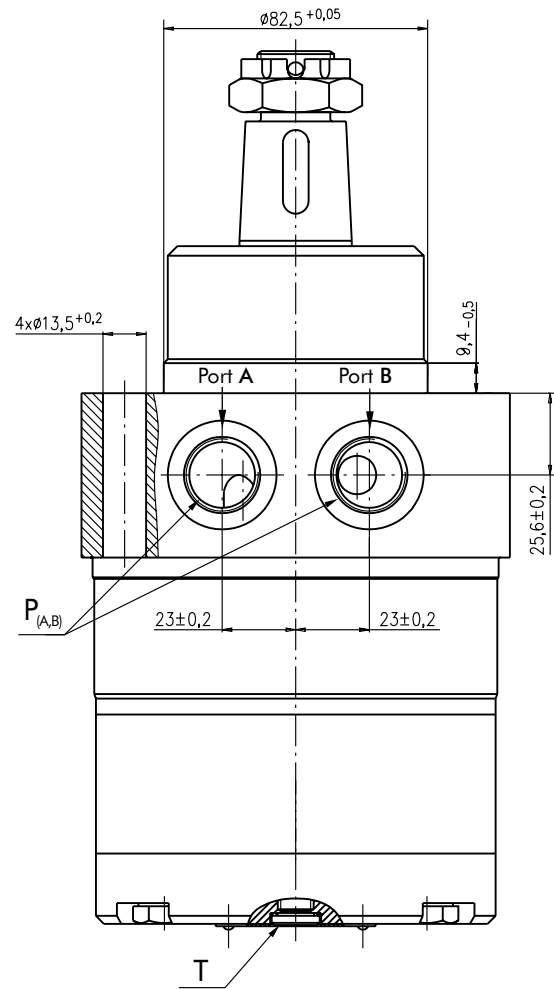
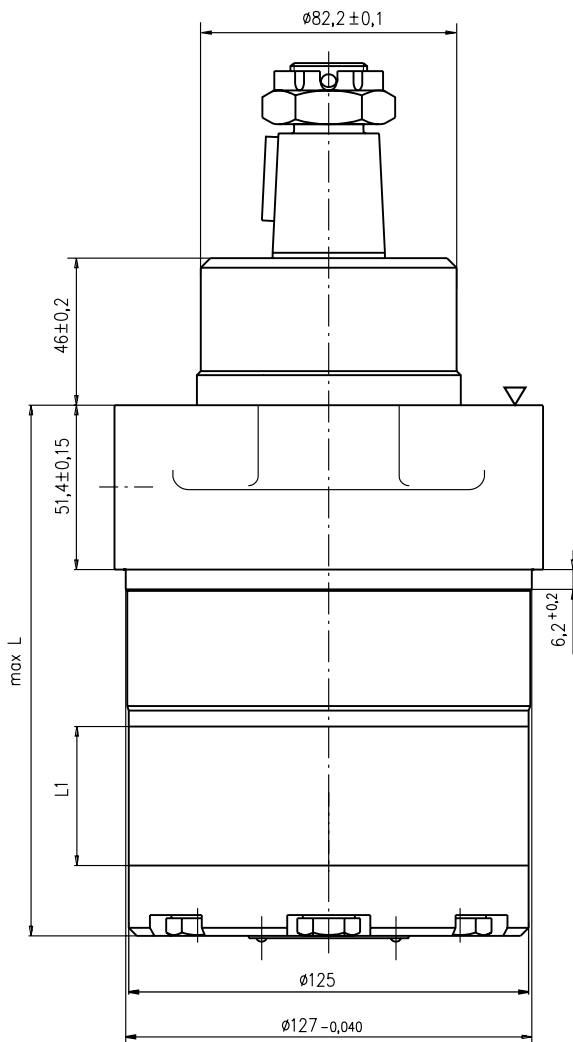

▽ - Motor Mounting Surface

Standard Rotation

Viewed from Shaft End
 Port A Pressurized - CW
 Port B Pressurized - CCW

Reverse Rotation

Viewed from Shaft End
 Port A Pressurized - CCW
 Port B Pressurized - CW

Type	L, mm	L ₁ , mm
HW 125	140,5	17,4
HW 160	145,0	21,8
HW 200	151,0	27,8
HW 235	155,5	32,5
HW 250	158,0	34,8
HW 300	164,5	41,4
HW 315	166,5	43,5
HW 350	171,0	48,0
HW 370	174,0	51,0
HW 400	178,0	54,8
HW 470	188,0	65,0
HW 500	192,5	69,4
HW 535	197,0	74,1
HW 550	199,0	76,0

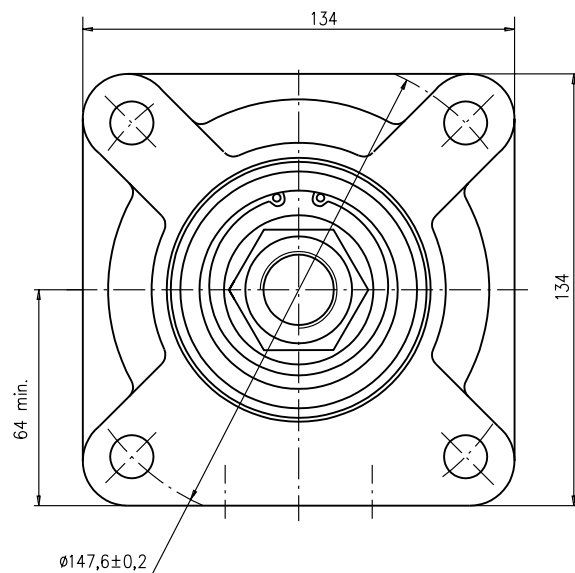

	Versions	
	2	4
P _(A,B)	2xG ¹ / ₂	2x ⁷ / ₈ -14UNF, O-ring
T	G ¹ / ₄	⁷ / ₁₆ -20UNF, O-ring

SHAFT EXTENSIONS

K - 1 1/4" straight, Parallel key 5/16"x5/16"x1 1/2" BS46
Max. Torque 77 daNm

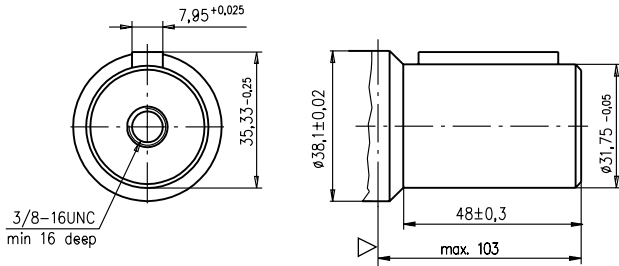

M - ø32 straight, Parallel key A10x8x32 DIN 6885
Max. Torque 77 daNm

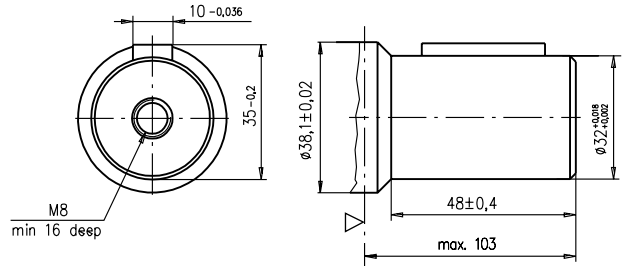

L - ø1 1/4" splined 14T, DP12/24 ANSI B92.1-1976 Norm
Max. Torque 77 daNm

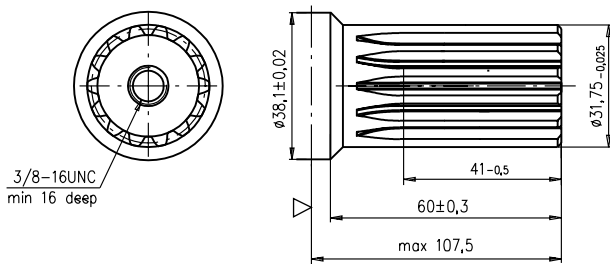

KB - ø35 tapered 1:10, Parallel key 5/16"x5/16"x1 1/4" BS46
Max. Torque 95 daNm

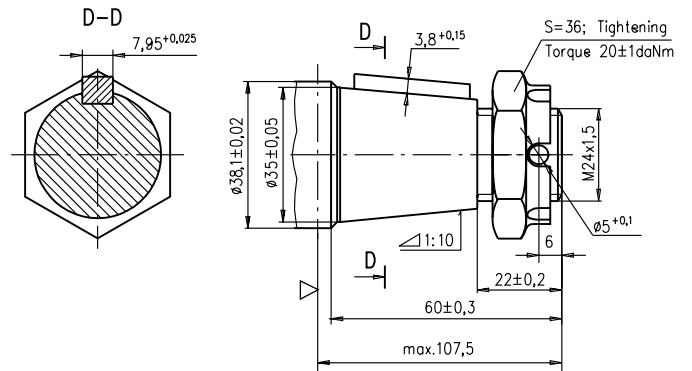

T - 1 1/2" tapered 1:8, Parallel key 5/16"x5/16"x1 1/4" BS46
Max. Torque 120 daNm

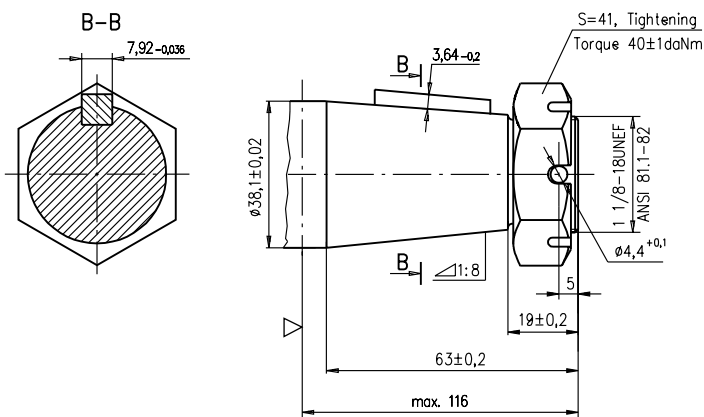

R - 1 1/4" tapered 1:8, Parallel key 5/16"x5/16"x1" BS46
Max. Torque 77 daNm

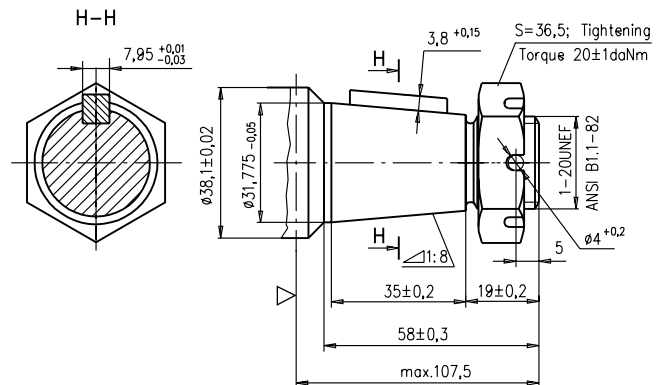

▽ - Motor Mounting Surface

PERMISSIBLE SHAFT LOADS

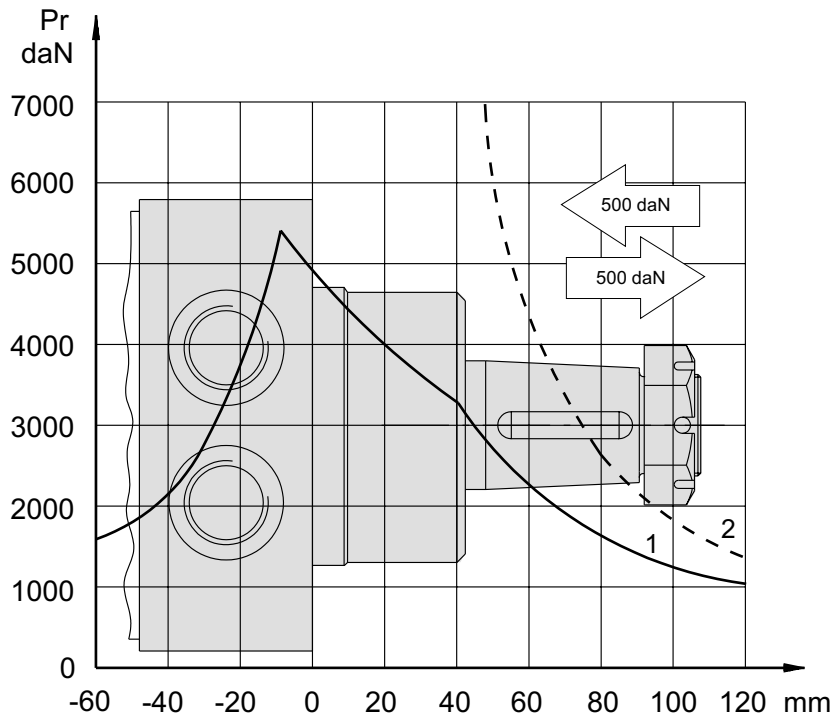

- 1 - Bearing curve: The curve applies to a B10 bearing life of 2000 hours at 100 RPM.
- 2 - Shaft curve: The curve represents Max. permissible radial shaft load with safety factor 3:1.

MAX. PERMISSIBLE SHAFT SEAL PRESSURE

HW... motors with drain connection:

The shaft seal pressure equals the pressure in the drain line.

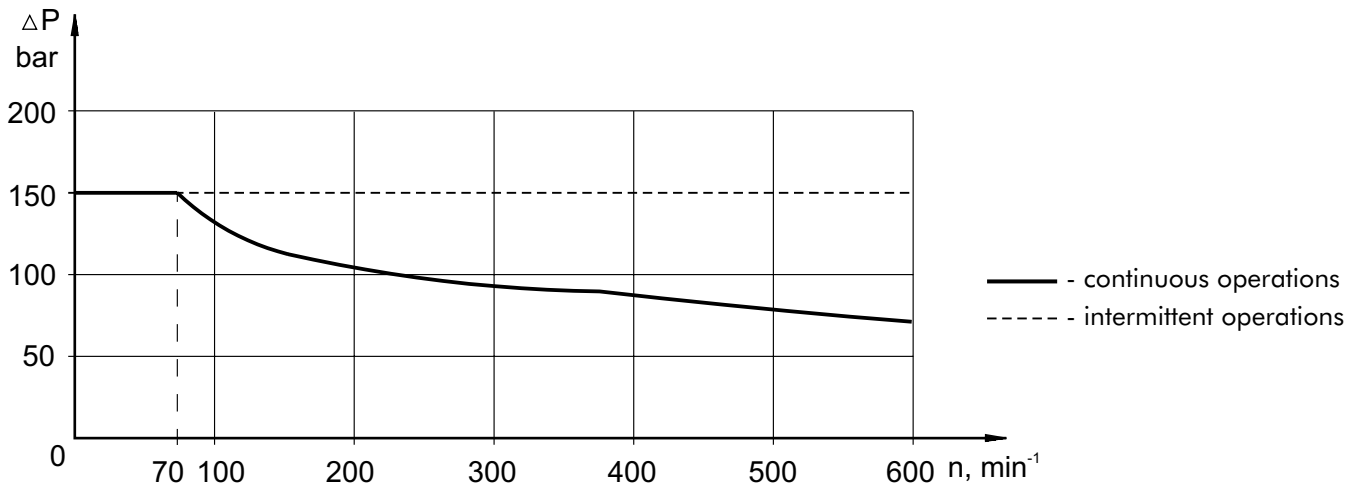
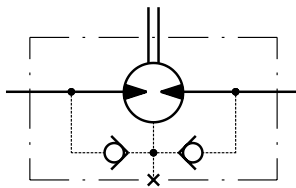

ORDER CODE

	1	2	3	4	5
HW					

Pos. 1 - Displacement code

125	- 126,00 [cm ³ /rev]
160	- 158,00 [cm ³ /rev]
200	- 201,30 [cm ³ /rev]
235	- 235,00 [cm ³ /rev]
250	- 252,00 [cm ³ /rev]
300	- 300,00 [cm ³ /rev]
315	- 314,90 [cm ³ /rev]
350	- 347,80 [cm ³ /rev]
370	- 369,00 [cm ³ /rev]
400	- 396,80 [cm ³ /rev]
470	- 470,60 [cm ³ /rev]
500	- 502,40 [cm ³ /rev]
535	- 536,00 [cm ³ /rev]
550	- 550,00 [cm ³ /rev]

Pos. 3 - Ports

2	- BSPP (ISO 228)
4	- SAE (ANSI B1.1-1982)

Pos. 4 - Special Features [\(see page 53\)](#)

Pos. 5 - Design Series

omit - Factory specified

Pos. 2 - Shaft Extensions*

K	- 1 1/4"[31,75] straight, Parallel key $\frac{5}{16}$ "x $\frac{5}{16}$ "x1 1/2" BS46
KB	- \varnothing 35 tapered 1:10, Parallel key $\frac{5}{16}$ "x $\frac{5}{16}$ "x1 1/4" BS46
L	- 1 1/4"[31,75] splined 14T, ANSI B92.1-1976
M	- \varnothing 32 straight, Parallel key A10x8x32 DIN 6885
R	- 1 1/4"[31,75] Tapered 1:8, Parallel key $\frac{5}{16}$ "x $\frac{5}{16}$ "x1" BS46
T	- 1 1/2"[38,1] Tapered 1:8, Parallel key $\frac{5}{16}$ "x $\frac{5}{16}$ "x1 1/4" BS46

NOTE: * The permissible output torque for shafts must not be exceeded!

The hydraulic motors are mangano-phosphatized as standard.

HYDRAULIC MOTORS PK



APPLICATION

- » Conveyors
- » Feeding mechanism of robots and manipulators
- » Metal working machines
- » Textile machines
- » Machines for agriculture
- » Food industries
- » Mining machinery etc.

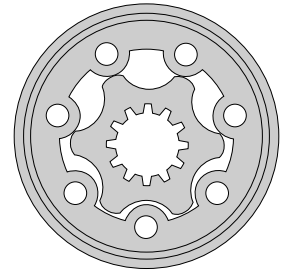

CONTENTS

Specification data 41
 Dimensions and mounting ... 42
 Shaft extensions 43
 Order code 43

OPTIONS

- » Model- Spool valve, gerotor
- » Antifriction conical bearing
- » Flange mount
- » Shafts- straight, splined and tapered
- » Metric and BSPP ports
- » Other special features

GENERAL

Displacement, [cm ³ /rev.]	49,5 ÷ 396
Max. Speed, [RPM]	150 ÷ 1210
Max. Torque, [daNm]	9,4 ÷ 41
Max. Output, [kW]	3,4 ÷ 5,2
Max. Pressure Drop, [bar]	95 ÷ 140
Max. Oil Flow, [l/min]	40 ÷ 60
Min. Speed, [RPM]	10
Permissible Shaft Loads, [daN]	P _a = 500
Pressure fluid	Mineral based- HLP(DIN 51524) or HM(ISO 6743/4)
Temperature range, [°C]	-30 ÷ 90
Optimal Viscosity range, [mm ² /s]	20 ÷ 75
Filtration	ISO code 20/16 (Min. recommended fluid filtration of 25 micron)

Oil flow in drain line

Pressure drop (bar)	Viscosity (mm ² /s)	Oil flow in drain line (l/min)
100	20	2,5
	35	1,8
140	20	3,5
	35	2,8

Pressure Losses

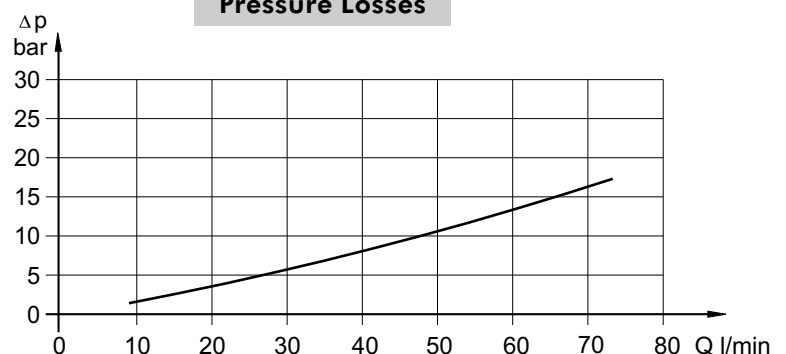

SPECIFICATION DATA

Type		PK 50	PK 80	PK 100	PK 125	PK 160	PK 200	PK 250	PK 315	PK 400
Displacement, [cm.³/rev.]		49,5	79,2	99	123,8	158,4	198	247,5	316,8	396
Max. Speed, [RPM]	Cont.	808	505	404	323	252	202	160	126	100
	Int.*	1010	630	505	403	315	252	202	157	126
Max. Torque [daNm]	Cont.	7	10,8	14,4	17	22	27,5	30,1	31,7	40,8
	Int.*	9,2	14,6	18,3	22,9	29,3	36,6	37,6	44	55,6
	Peak**	13,6	21,4	26,1	32,6	41,8	52,2	51,5	64,3	80
Max. Output [kW]	Cont.	5,2	5,2	5,2	5,2	5,2	5,2	4,6	3,4	3,4
	Int.*	8,6	8,6	8,6	8,6	8,6	8,6	7	5,8	5,8
Max. Pressure Drop [bar]	Cont.	105	105	105	105	105	105	90	70	70
	Int.*	140	140	140	140	140	140	115	105	105
	Peak**	215	215	215	215	215	215	170	170	170
Max. Oil Flow [l/min]	Cont.	40	40	40	40	40	40	40	40	40
	Int.*	50	50	50	50	50	50	50	50	50
Max. Inlet Pressure [bar]	Cont.	140	140	140	140	140	140	140	140	140
	Int.*	175	175	175	175	175	175	175	175	175
	Peak**	225	225	225	225	225	225	225	225	225
Max. Return Pressure without Drain	Cont. 0-100 RPM	150	150	150	150	150	150	150	150	150
	Cont. 100-300 RPM	75	75	75	75	75	75	75	75	75
Line or Max. Pressure in Drain Line, [bar]	Cont. 300-600 RPM	50	50	50	50	50	50	50	50	50
	Cont. >600 RPM	20	20	20	20	20	20	20	20	20
	Int.* 0-max. RPM	15	15	15	15	15	15	15	15	15
Max. Starting Pressure with Unloaded Shaft, [bar]		10	10	10	10	10	10	10	10	10
Min. Starting Torque [daNm]		5,8	9,1	12,2	14,5	19,5	24,8	27,5	29	35,9
Min. Speed***, [RPM]		10	10	10	10	10	10	10	10	10
Weight, [kg]		5	5,1	5,3	5,4	5,6	5,8	6	6,3	6,8

* Intermittent operation: the permissible values may occur for max. 10% of every minute.

** Peak load: the permissible values may occur for max. 1% of every minute.

*** For speeds of 10 RPM or lower, consult factory or your regional manager.

1. Intermittent speed and intermittent pressure drop must not occur simultaneously.
2. Recommended filtration is per ISO cleanliness code 20/16. A nominal filtration of 25 micron or better.
3. Recommended using a premium quality, anti-wear type mineral based hydraulic oil HLP(DIN51524) or HM (ISO 6743/4).
If using synthetic fluids consult the factory for alternative seal materials.
4. Recommended minimum oil viscosity 13 mm²/s at operating temperatures.
5. Recommended maximum system operating temperature is 82°C.
6. To assure optimum motor life fill with fluid prior to loading and run at moderate load and speed for 10-15 minutes.

OUTLINE DIMENSIONS REFERENCE

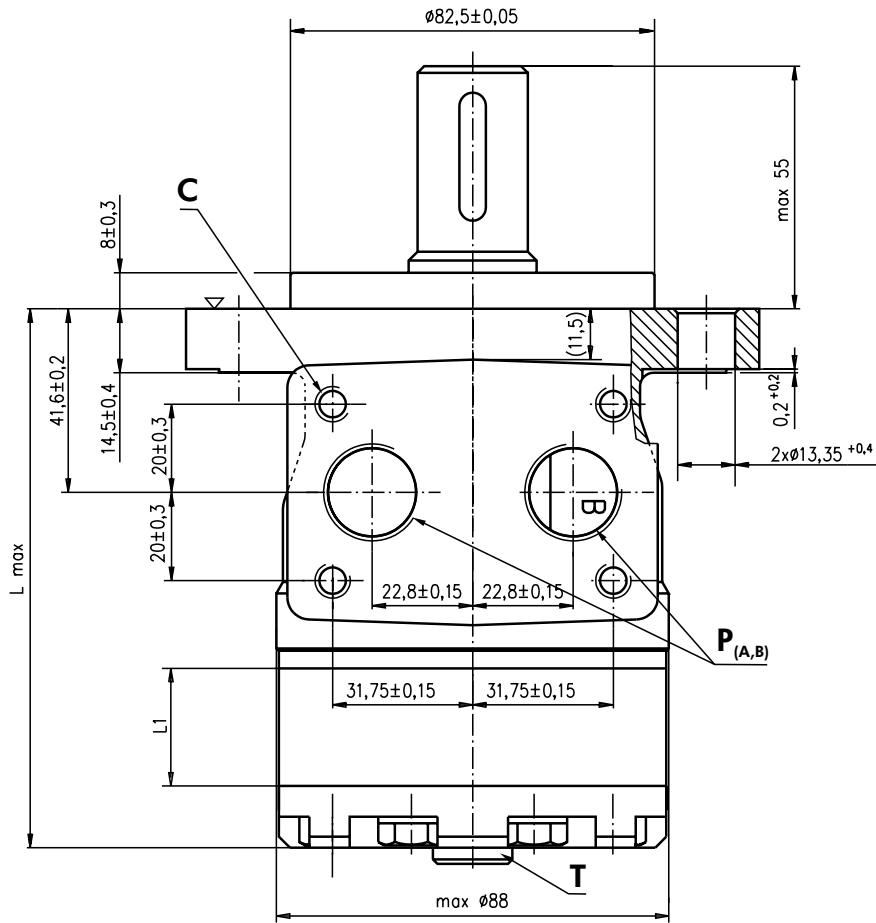

Standard Rotation
Viewed from Shaft End
Port A Pressurized - CW
Port B Pressurized - CCW

Reverse Rotation
Viewed from Shaft End
Port A Pressurized - CCW
Port B Pressurized - CW

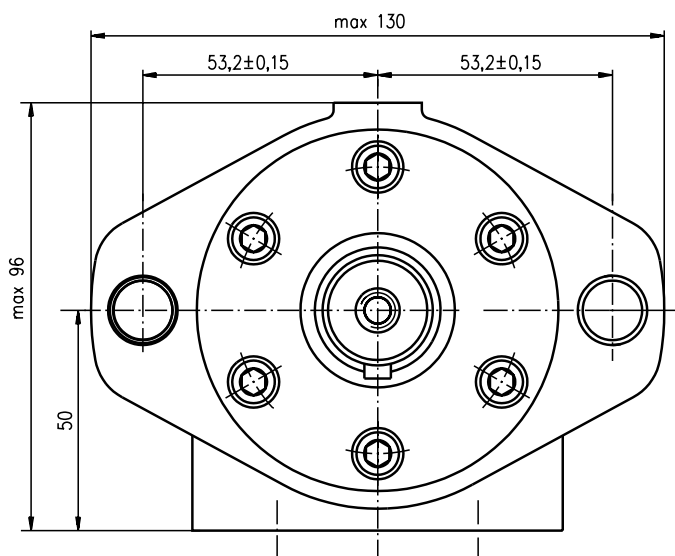

Type	L, mm	L ₁ , mm
PK 50	102,5	6,67
PK 80	106,5	10,67
PK 100	109	13,33
PK 125	112,5	16,67
PK 160	117	21,33
PK 200	122,5	26,67
PK 250	129	33,33
PK 300	138,5	42,67
PK 400	149	53,33

C : 4xM8 - 13 mm depth
P_(A, B) : 2xG1/2 or 2xM22x1,5 - 15 mm depth
T : G1/4 or M14x1,5 - 8,5 mm depth (plugged)

SHAFT EXTENSIONS

C $\varnothing 25$ straight, Parallel key A8x7x32 DIN 6885
Max. Torque 34 daNm

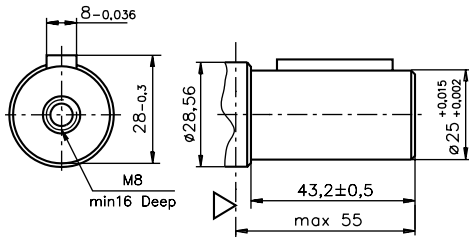

CO $\varnothing 25,4$ straight, Parallel key $1/4" \times 1/4" \times 1 1/4"$ BS46
Max. Torque 34 daNm

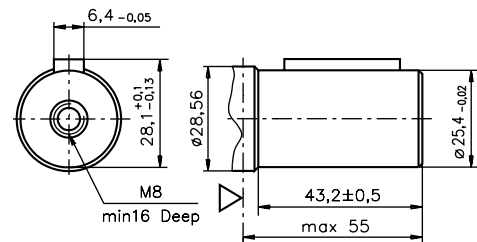

SH Splined, BS 2059 (SAE 6B)
Max. Torque 40 daNm

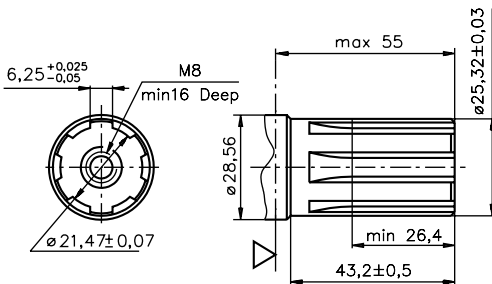

K Tapered 1:10 Parallel key B5x5x14 DIN 6885
Max. Torque 40 daNm

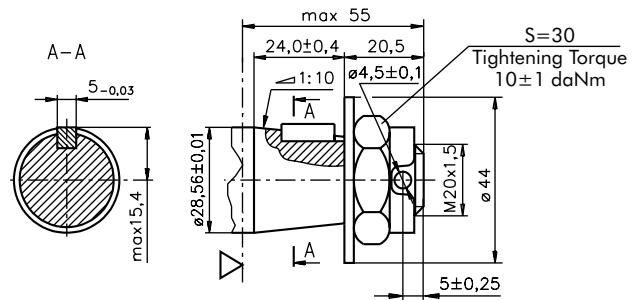

SA Splined, B25x22h9 DIN 5482
Max. Torque 40 daNm

▽ - Motor Mounting Surface

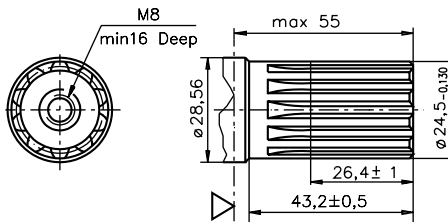

ORDER CODE

	1	2	3	4	5
PK					

Pos. 1 - Displacement code

50	- 49,5 [cm ³ /rev]
80	- 79,2 [cm ³ /rev]
100	- 99,0 [cm ³ /rev]
125	- 123,8 [cm ³ /rev]
160	- 158,4 [cm ³ /rev]
200	- 198,0 [cm ³ /rev]
250	- 247,5 [cm ³ /rev]
315	- 316,8 [cm ³ /rev]
400	- 398,0 [cm ³ /rev]

Pos. 2 - Shaft Extensions*

C	- $\varnothing 25$ straight, Parallel key A8x7x32 DIN6885
CO	- $\varnothing 25,4$ straight, Parallel key $1/4" \times 1/4" \times 1 1/4"$ BS46
SH	- $\varnothing 25,32$ splined BS 2059 (SAE 6B)
K	- $\varnothing 28,56$ tapered 1:10, Parallel key, B5x5x14 DIN6885
SA	- $\varnothing 24,5$ splined B25x22h9 DIN 5482

Pos. 3 - Ports

omit	- BSPP (ISO 228)
M	- Metric (ISO 262)

Pos. 4 - Special Features (see page 53)

Pos. 5 - Design Series

omit	- Factory specified
------	---------------------

NOTE:

* The permissible output torque for shafts must be not exceeded!

The hydraulic motors are mangano-phosphatized as standard.

HYDRAULIC MOTORS RK



APPLICATION

- » Conveyors
- » Feeding mechanism of robots and manipulators
- » Metal working machines
- » Textile machines
- » Machines for agriculture
- » Food industries
- » Mining machinery etc.

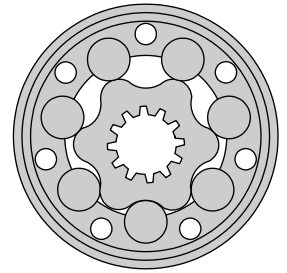

CONTENTS

Specification data	43
Dimensions and mounting ...	44
Shaft extensions	45
Order code	45

OPTIONS

- » Model- Spool valve, gerotor
- » Antifriction conical bearing
- » Flange mount
- » Shafts- straight, splined and tapered
- » Metric and BSPP ports
- » Other special features

GENERAL

Displacement, [cm ³ /rev.]	51,5 ÷ 397
Max. Speed, [RPM]	150 ÷ 775
Max. Torque, [daNm]	10 ÷ 40
Max. Output, [kW]	6,2 ÷ 10,8
Max. Pressure Drop, [bar]	75 ÷ 140
Max. Oil Flow, [l/min]	40 ÷ 60
Min. Speed, [RPM]	10
Permissible Shaft Loads, [daN]	P _a = 500
Pressure fluid	Mineral based- HLP(DIN 51524) or HM(ISO 6743/4)
Temperature range, [°C]	-30 ÷ 90
Optimal Viscosity range, [mm ² /s]	20 ÷ 75
Filtration	ISO code 20/16 (Min. recommended fluid filtration of 25 micron)

Oil flow in drain line

Pressure drop (bar)	Viscosity (mm ² /s)	Oil flow in drain line (l/min)
100	20	2,5
	35	1,8
140	20	3,5
	35	2,8

Pressure Losses

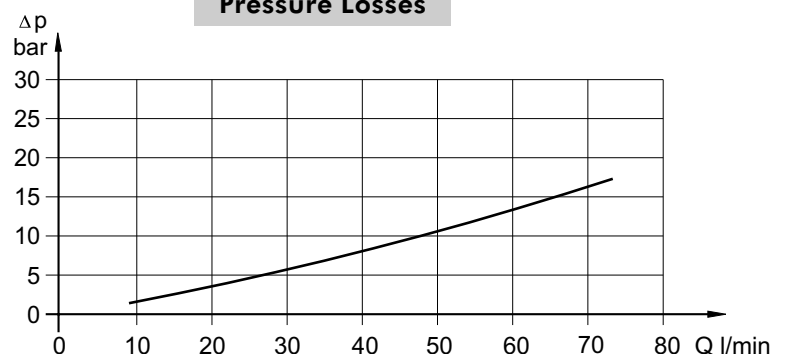

SPECIFICATION DATA

Type		RK 50	RK 80	RK 100	RK 125	RK 160	RK 200	RK 250	RK 315	RK 400
Displacement, [cm.³/rev.]		51,5	80,3	99,8	125,5	159,6	199,8	250,1	315,7	397
Max. Speed, [RPM]	Cont.	775	750	600	475	375	300	240	190	150
	Int.*	970	940	750	600	470	375	300	240	185
Max. Torque [daNm]	Cont.	10	15,7	19,8	25	32	34	40	40	40
	Int.*	13	19,5	24	30	39	42	47	50	50
	Peak**	17	27	32	37	46	56	64	65	65
Max. Output [kW]	Cont.	9	10,4	10,8	10,8	10,4	8,8	8,1	7,4	6,2
	Int.*	10,4	12,6	12,8	12,5	11,5	10,2	9,4	7,8	7,1
Max. Pressure Drop [bar]	Cont.	140	140	140	140	140	125	110	90	75
	Int.*	175	175	175	175	175	155	140	125	90
	Peak**	225	225	225	225	225	225	200	150	120
Max. Oil Flow [l/min]	Cont.	40	60	60	60	60	60	60	60	60
	Int.*	50	75	75	75	75	75	75	75	75
Max. Inlet Pressure [bar]	Cont.	175	175	175	175	175	175	175	175	175
	Int.*	200	200	200	200	200	200	200	200	200
	Peak**	225	225	225	225	225	225	225	225	225
Max. Return Pressure without Drain Line or Max. Pressure in Drain Line, [bar]	Cont. 0-100 RPM	150	150	150	150	150	150	150	150	150
	Cont. 100-300 RPM	75	75	75	75	75	75	75	75	75
	Cont. 300-600 RPM	50	50	50	50	50	50	50	50	50
	Cont. >600 RPM	20	20	20	20	20	20	20	20	20
	Int.* 0-max. RPM	15	15	15	15	15	15	15	15	15
Max. Starting Pressure with Unloaded Shaft, [bar]		10	10	10	10	10	10	10	10	10
Min. Starting Torque [daNm]		8	12	16	20	25	29	28	32	35
Min. Speed***, [RPM]		10	10	10	10	10	10	10	10	10
Weight, [kg]		6,2	6,3	6,6	6,7	6,9	7,4	7,8	8,5	9,3

* Intermittent operation: the permissible values may occur for max. 10% of every minute.

** Peak load: the permissible values may occur for max. 1% of every minute.

*** For speeds of 10 RPM or lower, consult factory or your regional manager.

1. Intermittent speed and intermittent pressure drop must not occur simultaneously.
2. Recommended filtration is per ISO cleanliness code 20/16. A nominal filtration of 25 micron or better.
3. Recommended using a premium quality, anti-wear type mineral based hydraulic oil HLP(DIN51524) or HM (ISO 6743/4).
If using synthetic fluids consult the factory for alternative seal materials.
4. Recommended minimum oil viscosity 13 mm²/s at operating temperatures.
5. Recommended maximum system operating temperature is 82°C.
6. To assure optimum motor life fill with fluid prior to loading and run at moderate load and speed for 10-15 minutes.

OUTLINE DIMENSIONS REFERENCE

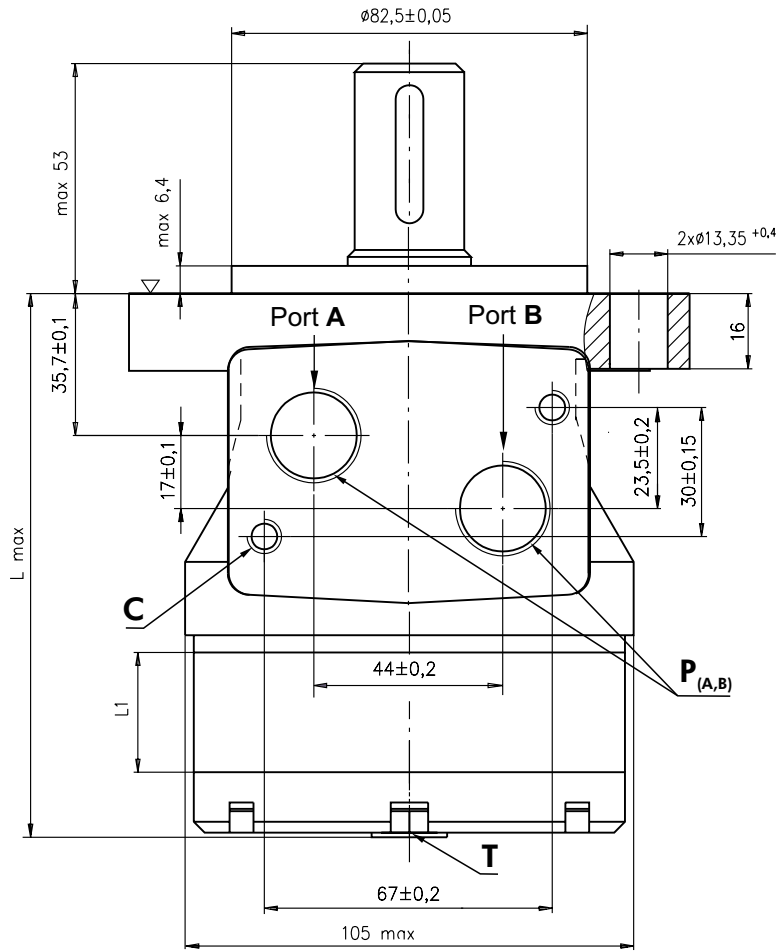

Standard Rotation
Viewed from Shaft End
Port A Pressurized - CW
Port B Pressurized - CCW

Reverse Rotation
Viewed from Shaft End
Port A Pressurized - CCW
Port B Pressurized - CW

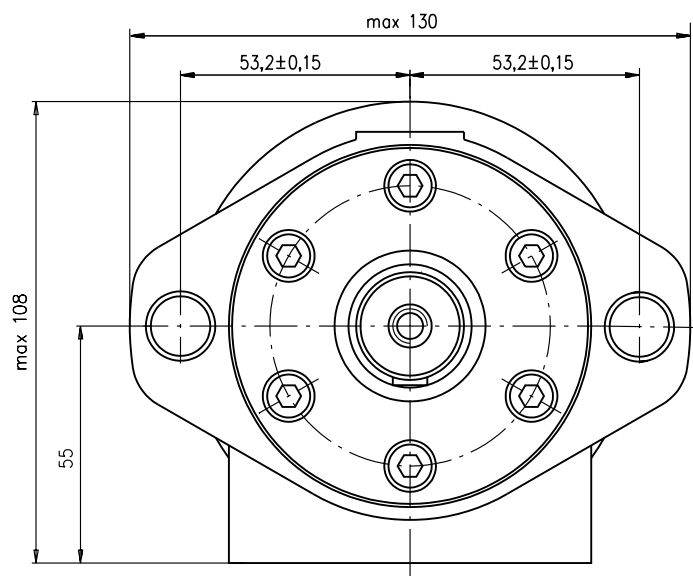

Type	L, mm	L ₁ , mm
RK 50	109,5	9,0
RK 80	114,5	14,0
RK 100	118	17,4
RK 125	122,5	21,8
RK 160	128,5	27,8
RK 200	135,5	34,8
RK 250	144	43,5
RK 300	155,5	54,8
RK 400	170	69,4

C : 2xM8 - 13 mm depth
P_(A,B) : 2xG1/2 - 15 mm depth
T : G1/4 - 8,5 mm depth (plugged)

SHAFT EXTENSIONS

C $\varnothing 25$ straight, Parallel key A8x7x32 DIN 6885
Max. Torque 34 daNm

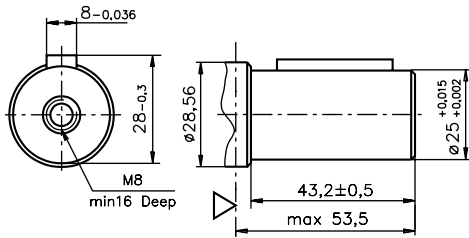

CO $\varnothing 25,4$ straight, Parallel key $1/4" \times 1/4" \times 1 1/4"$ BS46
Max. Torque 34 daNm

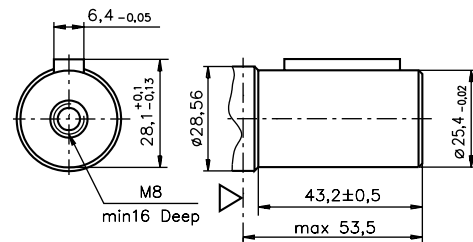

SH Splined, BS 2059 (SAE 6B)
Max. Torque 40 daNm

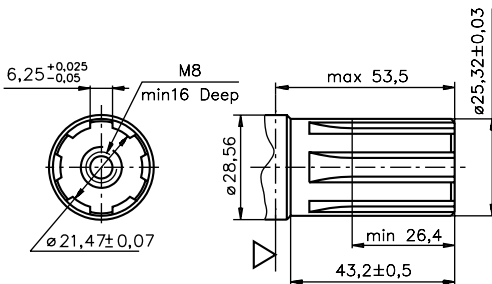

K Tapered 1:10 Parallel key B5x5x14 DIN 6885
Max. Torque 40 daNm

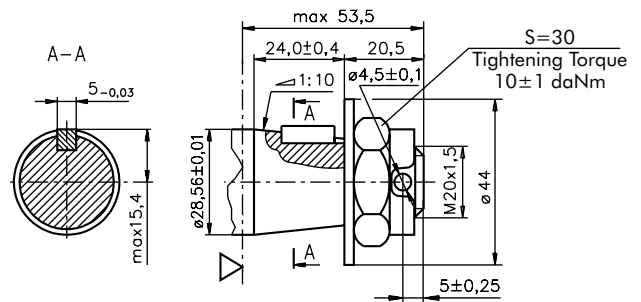

SA Splined, B25x22h9 DIN 5482
Max. Torque 40 daNm

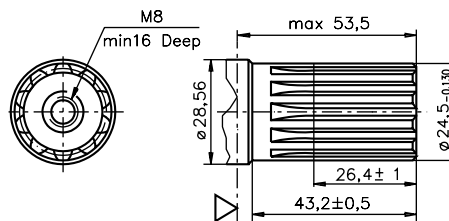

▽ Motor Mounting Surface

ORDER CODE

	1	2	3	4
RK				

Pos. 1 - **Displacement code**

50	- 51,5 [cm ³ /rev]
80	- 80,3 [cm ³ /rev]
100	- 99,8 [cm ³ /rev]
125	- 125,7 [cm ³ /rev]
160	- 159,6 [cm ³ /rev]
200	- 199,8 [cm ³ /rev]
250	- 250,1 [cm ³ /rev]
315	- 315,7 [cm ³ /rev]
400	- 397,0 [cm ³ /rev]

Pos. 2 - **Shaft Extensions***

C	- $\varnothing 25$ straight, Parallel key A8x7x32 DIN6885
CO	- $\varnothing 25,4$ straight, Parallel key $1/4" \times 1/4" \times 1 1/4"$ BS46
SH	- $\varnothing 25,32$ splined BS 2059 (SAE 6B)
K	- $\varnothing 28,56$ tapered 1:10, Parallel key, B5x5x14 DIN6885
SA	- $\varnothing 24,5$ splined B25x22h9 DIN 5482

Pos. 3 - **Special Features** (see page 53)

Pos. 4 - **Design Series**

omit - Factory specified

NOTE:

* The permissible output torque for shafts must not be exceeded!

The hydraulic motors are mangano-phosphatized as standard.

HYDRAULIC MOTOR-BRAKE B/MR

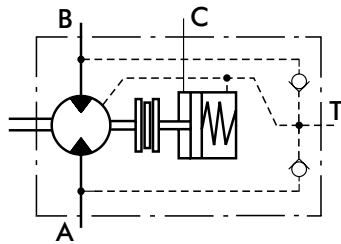

APPLICATION

- » Conveyors
- » Feeding mechanism of robots and manipulators
- » Metal working machines
- » Textile machines
- » Machines for agriculture
- » Food industries
- » Mining machinery etc.

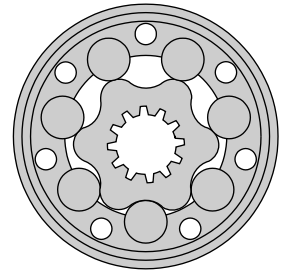

CONTENTS

Specification data	49 ÷ 50
Dimensions and mounting	51
Shaft extensions	51
Permissible shaft loads	52
Permissible shaft Seal Pressure ...	52
Order code	52

OPTIONS

- » Model- Spool valve, roll-gerotor;
- » Fully integrated friction disk brake;
- » Side port;
- » Shaft - straight;
- » BSPP ports.

GENERAL

Displacement, [cm ³ /rev.]	80,3 ÷ 397
Max. Speed, [RPM]	150 ÷ 500
Max. Torque, [daNm]	19,5 ÷ 55
Max. Output, [kW]	2,2 ÷ 16
Max. Pressure Drop, [bar]	45 ÷ 175
Max. Oil Flow, [l/min]	40 ÷ 60
Min. Speed, [RPM]	10
Permissible Shaft Loads, [daN]	P _a = 200
Pressure fluid	Mineral based- HLP(DIN 51524) or HM(ISO 6743/4)
Temperature range, [°C]	-30 ÷ 90
Optimal Viscosity range, [mm ² /s]	20 ÷ 75
Filtration	ISO code 20/16 (Min. recommended fluid filtration of 25 micron)

Oil flow in drain line

Pressure drop (bar)	Viscosity (mm ² /s)	Oil flow in drain line (l/min)
100	20	2,5
	35	1,8
140	20	3,5
	35	2,8

Pressure Losses

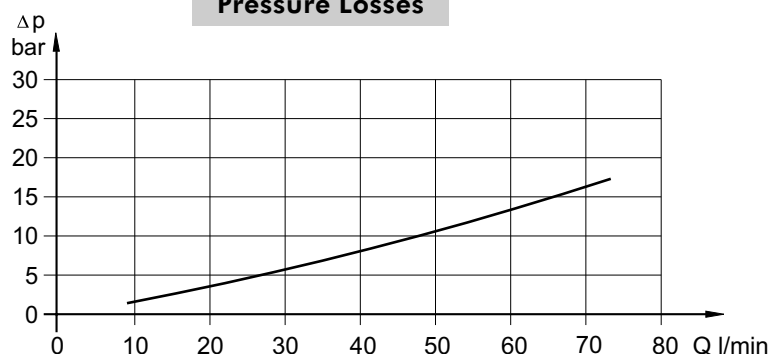

SPECIFICATION DATA

Type		B/MR 80	B/MR 100	B/MR 125	B/MR 160 C	B/MR 160 CB	B/MR 200 C	B/MR 200 CB
Displacement, cm.³/rev.		80,3	99,8	125,7	159,6		199,8	
Max. Speed, [min⁻¹]	Cont.	500	500	475	375		300	
	Int.*	600	600	600	470		375	
Max. Torque [daNm]	Cont.	19,5	24	30	30	39	30	45
	Int.*	22	28	34	39	43	39	50
	Peak**)	27	32	37	46	46	56	56
Max. Output [kW]	Cont.	16,6	18,6	12,5	10	11,5	7,8	11
	Int.*	16	16	14,5	12,5	14	12,4	13
Max. Pressure Drop, [bar]	Cont.	175	175	175	135	175	105	175
	Int.*	200	200	200	175	200	145	200
	Peak**	225	225	225	225	225	225	225
Max. Oil Flow [l/min]	Cont.	40	50	60	60		60	
	Int.*	48	60	75	75		75	
Max. Inlet Pressure [bar]	Cont.	175						
	Int.*	200						
	Peak**	225						
Max. Starting Pressure [bar]		10	10	9	7		5	
Min. Starting Torque, [daNm]	At max.press.dropCont	15	20	25	24	32	26	41
	At max.press.dropInt.*	17	23	28	32	37	33	46
Min. Speed***, [min⁻¹]		10	10	10	10	10	10	10
Static Torque of Brake, [daNm]		55						
Min. Brake Release Pressure****, [bar]		21						
Max. Opening Pressure, [bar]		200						
Weight, [kg]		11,0	11,2	11,4	11,6	11,7	12,2	12,3

* Intermittent operation: the permissible values may occur for max. 10% of every minute.

** Peak load: the permissible values may occur for max. 1% of every minute.

*** For speeds of 10 RPM or lower, consult factory or your regional manager.

**** Motor-brakes must always have a drain line. The brake release pressure is the difference between the pressure in the brake release line and the pressure in the drain line.

1. Intermittent speed and intermittent pressure drop must not occur simultaneously.
2. Recommended filtration is per ISO cleanliness code 20/16. A nominal filtration of 25 micron or better.
3. Recommended using a premium quality, anti-wear type mineral based hydraulic oil HLP(DIN51524) or HM (ISO 6743/4).
If using synthetic fluids consult the factory for alternative seal materials.
4. Recommended minimum oil viscosity 13 mm²/s at operating temperatures.
5. Recommended maximum system operating temperature is 82°C.
6. To assure optimum motor life fill with fluid prior to loading and run at moderate load and speed for 10-15 minutes.

SPECIFICATION DATA (continued)

Type		B/MR 250 C	B/MR 250 CB	B/MR 315 C	B/MR 315 CB	B/MR 400 C	B/MR 400 CB
Displacement, cm.³/rev.		250,1		315,7		397	
Max. Speed, [min⁻¹]	Cont.	240		190		150	
	Int.*	300		240		190	
Max. Torque [daNm]	Cont.	30	54	30	55	30	55
	Int.*	39	57	42	57	43	57
	Peak**)	60	71	61	71	60	70
Max. Output [kW]	Cont.	6,2	10	4,5	9	2,2	7
	Int.*	9,5	11	7,5	10	5,6	8,7
Max. Pressure Drop, [bar]	Cont.	85	175	65	135	45	105
	Int.*	115	185	90	145	75	115
	Peak**	200	225	150	180	120	140
Max. Oil Flow [l/min]	Cont.	60					
	Int.*	75					
Max. Inlet Pressure [bar]	Cont.	175					
	Int.*	200					
	Peak**	225					
Max. Starting Pressure [bar]		5		5		5	
Min. Starting Torque, [daNm]	At max.press.drop Cont	24	50	26	50	24	44
	At max.press.drop Int.*	31	51,5	35	51,8	38	50
Min. Speed***, [min⁻¹]		10	10	10	10	10	10
Static Torque of Brake, [daNm]		55					
Min. Brake Release Pressure****, [bar]		21					
Max. Opening Pressure, [bar]		200					
Weight, [kg]		12,6	12,7	13,3	13,4	14	14,1

* Intermittent operation: the permissible values may occur for max. 10% of every minute.

** Peak load: the permissible values may occur for max. 1% of every minute.

*** For speeds of 10 RPM or lower, consult factory or your regional manager.

**** Motor-brakes must always have a drain line. The brake release pressure is the difference between the pressure in the brake release line and the pressure in the drain line.

1. Intermittent speed and intermittent pressure drop must not occur simultaneously.
2. Recommended filtration is per ISO cleanliness code 20/16. A nominal filtration of 25 micron or better.
3. Recommended using a premium quality, anti-wear type mineral based hydraulic oil HLP(DIN51524) or HM (ISO 6743/4).
If using synthetic fluids consult the factory for alternative seal materials.
4. Recommended minimum oil viscosity 13 mm²/s at operating temperatures.
5. Recommended maximum system operating temperature is 82°C.
6. To assure optimum motor life fill with fluid prior to loading and run at moderate load and speed for 10-15 minutes.

OUTLINE DIMENSINS REFERENCE

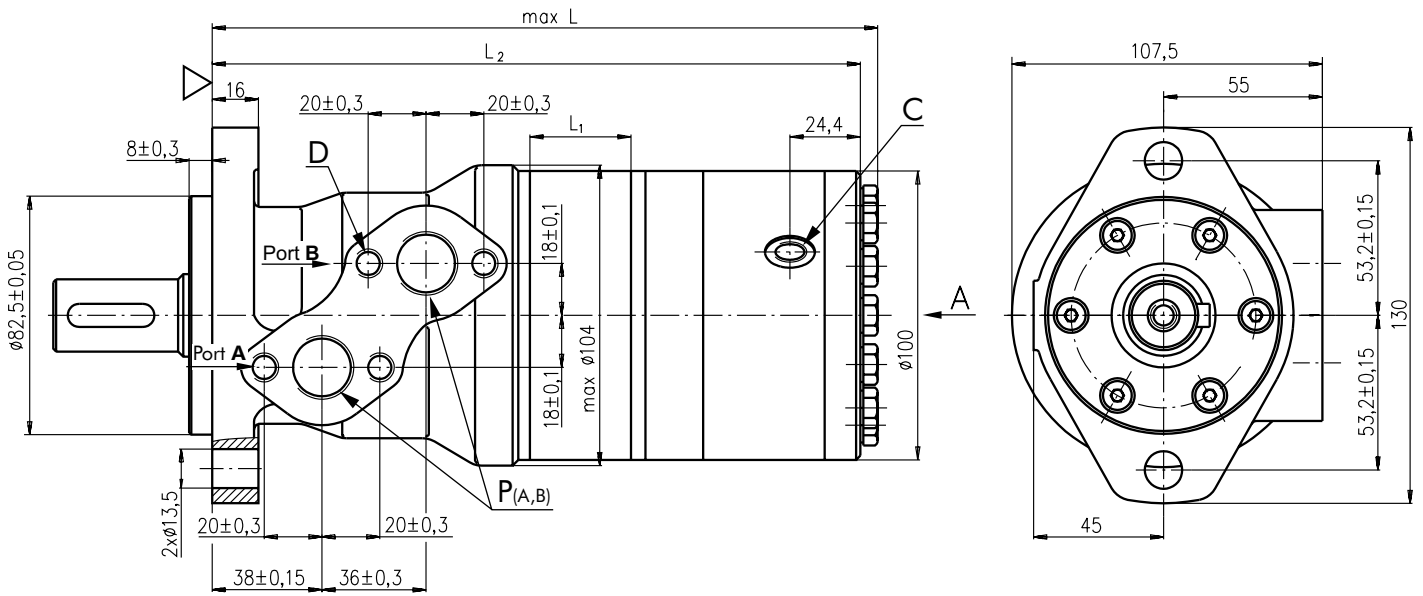

- D** : 4xM8 - 13 mm depth
- C** : G1/4 - 12 mm depth
- P_(A,B)**: 2xG1/2 - 15 mm depth
- T** : G1/4 - 10 mm depth

Type	L ₁ , mm	L ₂ , mm	L _{max} , mm
B/MR 80	14,0	205,5	213,5
B/MR 100	17,4	209,0	217,0
B/MR 125	21,8	213,5	221,5
B/MR 160	27,8	219,5	227,5
B/MR 200	34,8	226,5	234,5
B/MR 250	43,5	235,0	243,0
B/MR 315	54,8	246,5	254,5
B/MR 400	69,4	261,0	269,0

- Standard Rotation**
Viewed from Shaft End
Port **A** Pressurized - **CW**
Port **B** Pressurized - **CCW**
- Reverse Rotation**
Viewed from Shaft End
Port **A** Pressurized - **CCW**
Port **B** Pressurized - **CW**

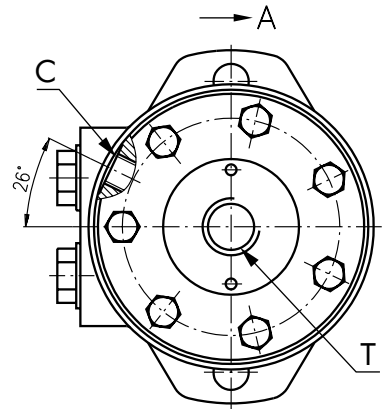

▽ - Motor Mounting Surface

SHAFT EXTENSIONS

C - $\varnothing 25$ straight, Parallel key A8x7x32 DIN 6885
Max. Torque 34 daNm

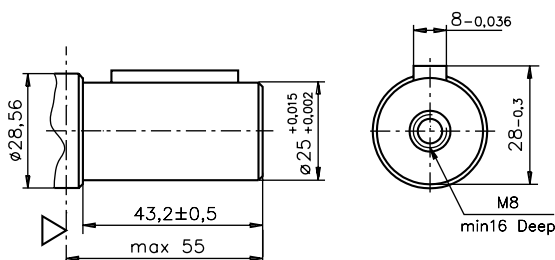

CB - $\varnothing 32$ straight, Parallel key A10x8x45 DIN 6885
Max. Torque 77 daNm

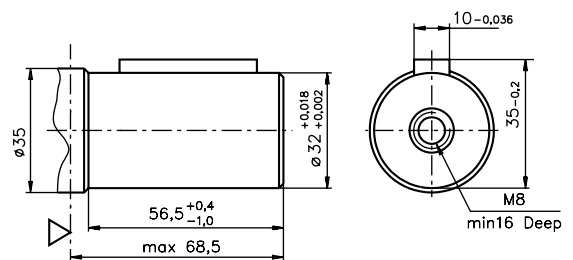

PERMISSIBLE SHAFT LOADS

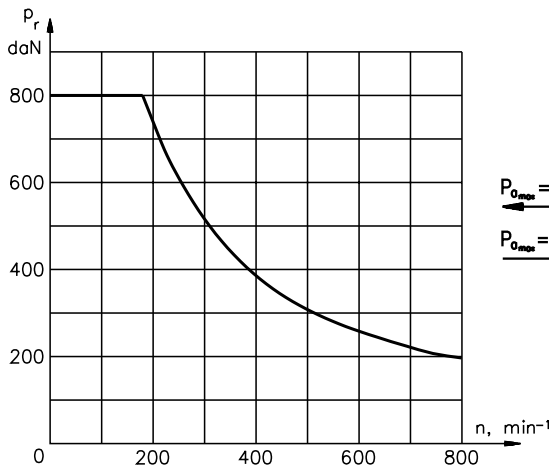

$P_{0_{max}} = 150 \text{ daN}$

$P_{0_{max}} = 200 \text{ daN}$

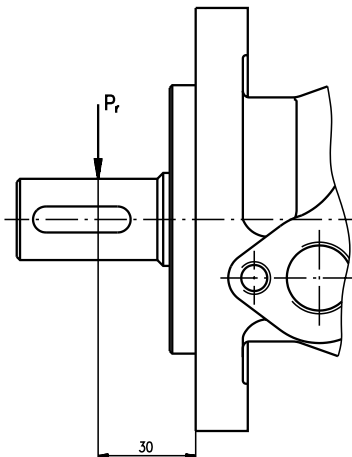

For Rotation speed $n \geq 200 \text{ min}^{-1}$ and distance $L \neq 30 \text{ mm}$ the radial load could be calculated by

$$P_r = \frac{800}{n} \times \frac{25\,000}{95+L}, \text{ daN}$$

MAX. PERMISSIBLE SHAFT SEAL PRESSURE

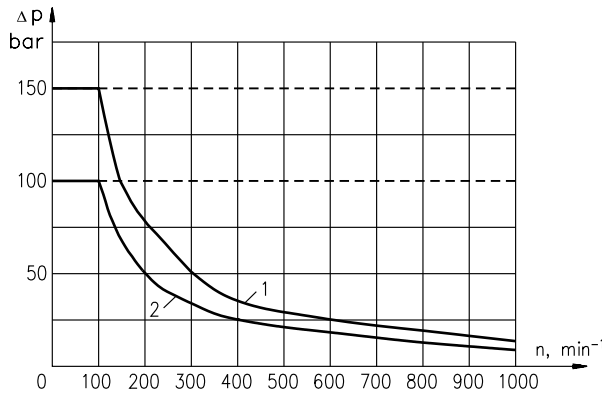

1: Drawing for "C" shaft

2: Drawing for "CB" shaft

—— - continuous operations

----- - intermittent operations

ORDER CODE

	1	2	3	4
B/MR				

Pos. 1 - Displacement code

80	- 80,3 [cm ³ /rev]
100	- 99,8 [cm ³ /rev]
125	- 125,7 [cm ³ /rev]
160	- 159,6 [cm ³ /rev]
200	- 199,8 [cm ³ /rev]
250	- 250,1 [cm ³ /rev]
315	- 315,7 [cm ³ /rev]
400	- 397,0 [cm ³ /rev]

Pos. 2 - Shaft Extensions*

C	- ø25 straight, Parallel key A8x7x32 DIN 6885
CB	- ø32 straight, Parallel key A10x8x45 DIN 6885

Pos. 3 - Special Features (see page 53)

Pos. 4 - Design Series

omit - Factory specified

NOTES:

* The permissible output torque for shafts must be not exceeded!

The hydraulic motors are manganophosphatized as standard.

MOTOR SPECIAL FEATURES

Special Feature Description	Order Code	Motor type						
		PL	RL	RW	HW	PK	RK	B/MR
Low Leakage	LL	○	○	○	○	○	○	○
Low Speed Valving	LSV	○	○	○	○	○	○	○
Free Running	FR	○	○	○	○	○	○	-
Reverse Rotation	R	○	○	○	○	○	○	○
Paint**	P	○	○	○	○	○	○	○
Corrosion Protected Paint*	PC	○	○	○	○	○	○	○
Check Valves		S	S	S	S	S	S	S

* color at customer's request.

- Optional
- Not applicable
- S Standard

MOTOR APPLICATION

VEHICLE DRIVE CALCULATIONS

1. Motor speed: n , [min^{-1}]

$$n = \frac{2,65 \times v \times i}{R}$$

v - vehicle speed, [km/h];

R - wheel rolling radius, [m];

i - gear ratio between motor and wheels.

If no gearbox, use $i = 1$.

2. Rolling resistance: RR , [daN]

The resistance force resulted in wheels contact with different surfaces:

$$RR = G \times \rho$$

G - total weight loaded on vehicle, [daN];

ρ - rolling resistance coefficient (Table 1).

Table 1

Rolling resistance coefficient In case of rubber tire rolling on different surfaces	
Surface	ρ
Concrete- faultless	0,010
Concrete- good	0,015
Concrete- bad	0,020
Asphalt- faultless	0,012
Asphalt- good	0,017
Asphalt- bad	0,022
Macadam- faultless	0,015
Macadam- good	0,022
Macadam- bad	0,037
Snow- 5 cm	0,025
Snow- 10 cm	0,037
Polluted covering- smooth	0,025
Polluted covering- sandy	0,040
Mud	$0,037 \div 0,150$
Sand- Gravel	$0,060 \div 0,150$
Sand- loose	$0,160 \div 0,300$

3. Grade resistance: GR , [daN]

$$GR = G \times (\sin \alpha + \rho \times \cos \alpha)$$

α - gradient negotiation angle (Table 2)

Table 2

Grade %	α Degrees	Grade %	α Degrees
1%	$0^\circ 35'$	12%	$6^\circ 5'$
2%	$1^\circ 9'$	15%	$8^\circ 31'$
5%	$2^\circ 51'$	20%	$11^\circ 19'$
6%	$3^\circ 26'$	25%	$14^\circ 3'$
8%	$4^\circ 35'$	32%	18°
10%	$5^\circ 43'$	60%	31°

4. Accelerate force: FA , [daN]

Force FA necessary for acceleration from 0 to maximum speed v and time t can be calculated with a formula:

$$FA = \frac{v \times G}{3,6 \times t}, [\text{daN}]$$

FA - accelerate force, [daN];

t - time, [s].

5. Tractive effort: DP , [daN]

Tractive effort DP is the additional force of trailer. This value will be established as follows:

-acc.to constructor's assessment;

-as calculating forces in items 2, 3 and 4 of trailer; the calculated sum corresponds to the tractive effort requested.

6. Total tractive effort: TE , [daN]

Total tractive effort TE is total effort necessary for vehicle motion; that the sum of forces calculated in items from 2 to 5 and increased with 10 % because of air resistance.

$$TE = 1,1 \times (RR + GR + FA + DP)$$

RR - force acquired to overcome the rolling resistance;

GR - force acquired to slope upwards;

FA - force acquired to accelerate (acceleration force);

DP - additional tractive effort (trailer).

7. Motor Torque: M , [daNm]

Necessary torque moment for every hydraulic motor:

$$M = \frac{TE \times R}{N \times i \times \eta_M}$$

N - motor numbers;

η_M - mechanical gear efficiency (if it is available).

8. Cohesion between tire and road covering: M_w , [daNm]

$$M_w = \frac{G_w \times f \times R}{i \times \eta_M}$$

To avoid wheel slipping, it should be observed the following condition $M_w > M$

f - frictional factor;

G_w - total weight over the wheels, [daN].

Table 3

Surface	Frictional factor f
Steel on steel	$0,15 \div 0,20$
Rubber tire on polluted surface	$0,5 \div 0,7$
Rubber tire on asphalt	$0,8 \div 1,0$
Rubber tire on concrete	$0,8 \div 1,0$
Rubber tire on grass	0,4

9.Radial motor loading: P_{rad} , [daN]

When motor is used for vehicle motion with wheels mounted directly on motor shaft, the total radial loading of motor shaft P_{rad} is a sum of motion force and weight force acting on one wheel.

G_w - Weight held by wheel;

P_{rad} - Total radial loading of motor shaft;

M/R - Motion force.

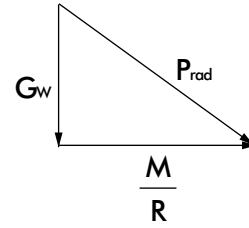

$$P_{rad} = \sqrt{G_w^2 + \left(\frac{M}{R}\right)^2}$$

In accordance with calculated loadings the suitable motor from the catalogue is selected.

DRAINAGE SPACE AND DRAINAGE PRESSURE

Advantages in oil drainage from drain space: Cleaning; Cooling and Seal lifetime prolonging.

